

*Installation,
Operation,
&
Maintenance
Manual*

Welker[®] Sampler

*Model
GSSM4*

The information in this manual has been carefully checked for accuracy and is intended to be used as a guide to operations. Correct operating and/or installation techniques, however, are the responsibility of the end user. Welker reserves the right to make changes to this and all products to improve performance and reliability.

13839 West Bellfort
Sugar Land, Texas 77498-1671
U.S.A.
Tel.: (800) 776-7267
Tel.: (281) 491-2331
Fax: (281) 491-8344
www.welkereng.com

TABLE OF CONTENTS

1. GENERAL	3
1.1 Introduction	3
1.2 Specifications	5
2. INSTALLATION INSTRUCTIONS	6
2.1 Installing the Sampler	6
2.2 Start-Up and Sequence of Operation	10
3. MAINTENANCE INSTRUCTIONS	14
3.1 General Information	14
3.2 Instructions	15
4. INLINE RELIEF INSTRUCTIONS.....	20
4.1 General Information	20
4.2 For Single-Cavity Cylinders.....	20
4.3 For Constant Pressure Cylinders.....	21
4.4 Inline Relief Maintenance.....	22

Welker®, Welker Jet®, and WelkerScope® are Registered Trademarks owned by Welker.

1. GENERAL

1.1 Introduction

We appreciate your business and your choice of Welker products. The Installation, Operation and Maintenance liability for this product becomes that of the purchaser at the time of receipt. Reading the applicable IO&M Manual prior to installation and operation of this equipment is required so that you have a full understanding of its application and performance prior to commencement of use. If you have any questions, please call 1-800-776-7267 or 1-281-491-2331 in the USA.

The Welker GSSM4 Gas Sampler is a pipe-mounted type sampler designed to extract a representative sample of the flowing product from the center one-third of the pipeline with the aid of a sample probe.

The GSSM4, with its “Vanishing Chamber” collection head, is capable of extracting a representative sample from the flowing stream and pumping the sample into a sample cylinder.

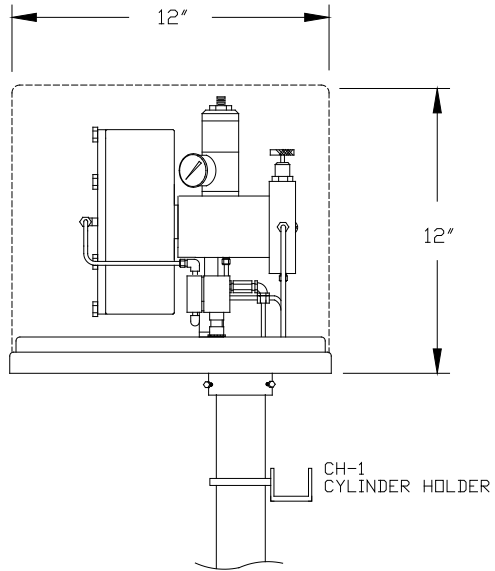

FIGURE 1

The GSSM4 sampling system does not require an external pneumatic supply (see Figure 1). This system uses the pipeline gas for the instrument pressure. By design, a unique self-purging system through the sample chamber area ensures a true representative sample with each sample cycle.

1.2 Specifications

Product Sampled	Natural gas, or other compatible gaseous fluids
Materials of Construction	316 stainless steel sampler and valves, aluminum regulator
Sample Grab Sizes	0.22, 0.5, 1.0, 1.5cc
Grab Rate	Up to 15 grabs per minute
Line Temperature Limit	-20°F (-28.9°C) to 250°F (121.1°C) standard
Maximum Line Pressure	3,600psi (248bar) standard
Pipe Mount Connection	2" Pipe standard
Sample Outlet Connection	1/4" FNPT
Area Classification	Can be used in hazardous areas

2. INSTALLATION INSTRUCTIONS

The installation instructions are written from the position that the GSSM4 is part of a complete sampler system. If it is purchased as a sample pump alone, the system should be constructed in a fashion compatible to the following instructions.

2.1 Installing the Sampler

To place the sampler into operation, the following steps should be followed:

- 2.1.1 After unpacking the unit, check it for compliance and any damages that may have occurred during shipment.

NOTE: Claims for damages caused during shipment must be initiated by the receiver to the carrier. Welker is not responsible for any damages caused from mishandling by the shipping company.

NOTE: When sealing fittings with PTFE tape, refer to the proper sealing instructions for the tape used.

- 2.1.2 A sample probe should be located in the least turbulent area available of the flowing stream, i.e., **not in a header or blow-down stack and away from obstructions, elbows or partially closed valves**. The sample probe should be installed reaching approximately into the center one-third of the pipeline.

NOTE: Typically the Welker Gas Sampler is installed utilizing a single sample probe. Its unique self-purging feature uses pipeline gas for the instrumentation supply source, thus purging the sample line prior to each sample grab. If instrument air is to be used for the instrument supply, the sampler should be installed with a pitot probe or with 2 single probes. If 2 single probes are used,

one should be located upstream and the other one downstream of a moderate pressure drop such as an orifice plate or control valve. This will create a hot loop for the sampler that will allow a “real-time” sample to be taken with each new actuation.

2.1.3 The sampler should be located as close to the sample point as practical and above the pipeline probe. A location up to three feet from the probe is desirable.

2.1.4 The sample probe valve should be a large ported valve (i.e. fully opening ball valve, block valve, etc.).

2.1.5 Once the sampler is mounted and the probe is installed, installation can be completed. Place your sample cylinder on the sample cylinder holder. The cylinder should be located as close to the sampler as possible.

2.1.6 If using a single-cavity sample cylinder, the in-line relief should be set at 100 psi above maximum line pressure (see Section 4).

2.1.7 If using a constant pressure sample cylinder, the inline relief should be set at approximately 200 psi and the cylinder must first be pre-charged.

2.1.8 Pre-charging a constant pressure sample cylinder with a pre-charge gas can be done one of three ways:

2.1.8.1 Connect the cylinder pre-charge valve to the pipeline (see Figure 2).

2.1.8.2 Connect the cylinder pre-charge valve to an extra port in the sampler probe (see Figure 2).

2.1.8.3 Auxiliary pre-charge gas

NOTE: If a constant pressure sample cylinder is used, refer to the instructions sent with the cylinder for complete details on pre-charging the cylinder.

2.1.9 If applicable, remove the sampler cover or dome for manifold identification.

2.1.10 Using small diameter stainless steel tubing (1/4" O.D.), tube from the probe to the inlet port of the manifold (labeled "inlet"). Where a hot loop or pitot probe is employed, tube to P₂ as previously discussed in 2.1.2. The tubing should always slope downward from the sampler to the probe and be free of sags and loops.

NOTE: Nothing should be installed between the probe and the inlet of the sampler, such as filters, drip pots or regulators. These will have an adverse effect on the integrity of the sample. Also, make sure that all fittings are tight and NPT connections are PTFE taped or doped.

2.1.11 Using 1/8" O.D. stainless steel tubing; connect from the sample outlet port to the sample inlet valve on the sample cylinder (see Figures 2 and 3).

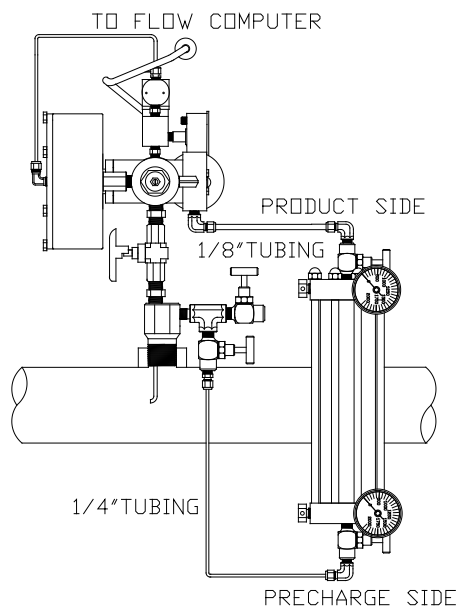
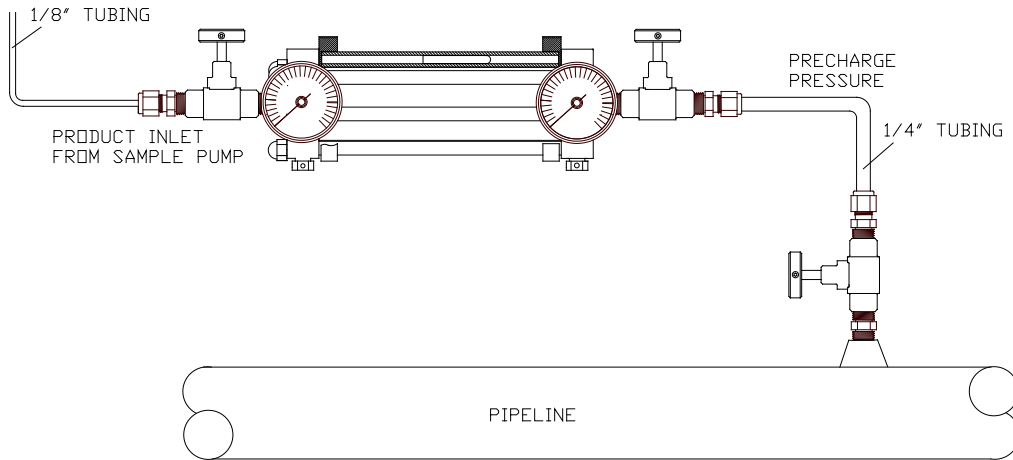

FIGURE 2

PURGE VALVE

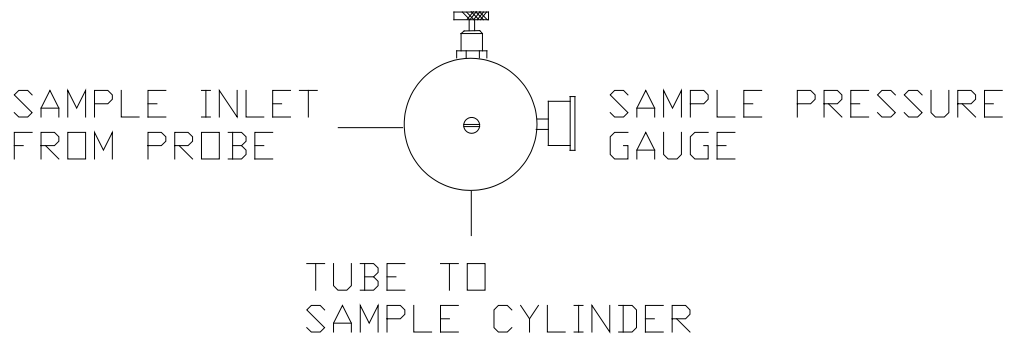

FIGURE 3

- 2.1.12 Close all valves on the sample cylinder.
- 2.1.13 If the sampler is to be actuated by an auxiliary air or gas supply as mentioned under 2.1.2, the unit will be supplied with a port tagged "air supply". Tube the instrument air supply to that port (80 to 100 psi minimum).
- 2.1.14 Connect the power supply to the sampler's mode of actuation.
- 2.1.14.1 For connection of the 4P controller, see the installation/operation manual included with 4P controller.
- 2.1.14.2 No external connections are required for the 6TC controller. For operation, see its installation/operation manual.
- 2.1.14.3 For samplers that are controlled from a customer-furnished remote controller, connect the remote controller output voltage signal to the 3-way solenoid on the GSSM4.
- 2.1.15 This completes the installation procedure.

2.2 Start-Up and Sequence of Operation

NOTE: When pressuring the system, always open pipeline valves slowly. All connections must be checked carefully for leaks at full line pressure. No leaks are acceptable within the complete sample system.

- 2.2.1 All valves are still closed on the sampler and sample cylinder.
- 2.2.2 For constant pressure cylinders, go to Section 2.2.3. For single-cavity sample cylinders, go to Section 2.2.11.
- 2.2.3 **Constant Pressure Cylinders** - Slowly open the pipeline gas supply valve to the pre-charge side of the constant pressure cylinder. Check for leaks.
- 2.2.4 Open the product inlet valve on the constant pressure cylinder.

2.2.5 Very slowly open the pre-charge valve on the constant pressure cylinder. This allows pre-charge pressure to be supplied to the cylinder and forces the piston to the product side if it is not already there.

2.2.6 Close the product inlet valve on the constant pressure cylinder.

2.2.7 Open the pipeline isolation valve that leads to the sampler. Make sure there are no leaks between the sampler and the cylinder.

NOTE: If your sampler was purchased to be used with a constant pressure cylinder, the inline relief is factory set at 200 psi. Therefore, the gauge on the sampler manifold will read approximately 200 psi below your pipeline pressure. If this setting is incorrect, see instructions to properly set the inline relief (see Section 4).

2.2.8 Open the product inlet valve on the constant pressure cylinder. Check for leaks and tighten any fittings that are leaking.

2.2.9 Purge the tubing between the sampler and cylinder by cracking the tube fitting on the cylinder inlet.

NOTE: If your constant pressure cylinder is equipped with a product purge valve, open it to purge the tubing for approximately 3-5 seconds and close. When possible, plug purge valve when not in use. If your cylinder is not equipped with a purge valve, we recommend that a “T” and a valve be used just prior to the inlet valve to provide a purge system.

2.2.10 You are now ready to begin the sampling timing cycles with the control system you chose.

2.2.11 **Single-Cavity Sample Cylinders** - Remember that the in-line relief must be set at 100 psi above maximum line pressure (see Section 4). Slowly open the pipeline isolation valve on the probe leading to the sampler.

NOTE: If your sampler was purchased to be used with a single-cavity sample cylinder, the gauge on the sampler manifold should read zero. Make sure that the cylinder valves are closed. Mount the standard cylinder in the vertical position.

2.2.12 Now slowly open the bypass valve on the sampler manifold. Using a leak check solution, check for leaks. Tighten any fittings that are leaking.

2.2.13 Once leaks are corrected, shut the bypass valve on the sampler manifold.

2.2.14 Purge the tubing between the sampler and cylinder by cracking the tube fitting on the cylinder inlet. Follow company procedure for preparing the standard cylinder for use.

2.2.15 Open the product inlet valve on the sample cylinder.

2.2.16 You are now ready to begin the sampling timing cycles with the control system you chose.

2.2.17 The instrument supply air should be set at 65-70psi. Set the instrument regulator relief valve at 85psi maximum.

NOTE: In cases where pipeline pressures are in excess of 1,500psi, more instrument supply air may be necessary to take a sample. The instrument supply will have to be increased accordingly. Increased supply air should be used only when necessary.

2.2.18 To test the sample system, take the following steps:

2.2.18.1 Make sure the bypass valve is closed on the manifold assembly.

- 2.2.18.2 Close the product inlet valve on the sample cylinder.
 - 2.2.18.3 Actuate the solenoid valve.
 - 2.2.18.4 Observe gauge on the sampler manifold base. Build pressure to above line pressure. Let the unit sit for several minutes and check for a drop in pressure. If it does drop, check for leaks. If the sampler holds pressure, the unit is ready to be placed in operation.
- 2.2.19 Bleed the test pressure off. Open the product inlet valve on the sample cylinder.
- 2.2.20 The sampler is ready for operation.

3. MAINTENANCE INSTRUCTIONS

NOTE: Refer to Figure 4.

3.1 General Information

Prior to maintenance or disassembly of the unit, it is advisable to have a repair kit handy for the system in case of encountering unexpected wear or faulty seals.

Important: Maintenance should be performed on the sampler only after it has been isolated from the pipeline and all pressure has been vented from the sampler.

We recommend that the unit have annual maintenance under normal operating conditions. In the case of severe service, dirty conditions, excessive cycling usage or other unique applications that may subject the equipment to unpredictable circumstances, a more frequent maintenance schedule may be appropriate.

Maintenance should be done in as clean a work area as possible.

New seals supplied in spare parts kits are not lubricated. They should be lightly coated with lubrication grease (silicone grease or other) before they are installed into the equipment. This helps in the installation of the seals while reducing the risk of damage when positioning them on the parts. After the seals are installed, some additional lubrication can be applied to shafts or cylinder inner diameters to allow smooth transition of parts. All O-rings and seals can be easily cut or damaged and, thus, destroyed. Reassemble the sampler with care. This is an instrument and should be handled accordingly. Lubricate all polished surfaces

and seals with silicone grease or similar lubricant. The following tools will be required for disassembly and maintenance.

- 1/2" wrench
- 6" adjustable wrench
- Hex wrenches 1/8" & 3/16"
- Adjustable pliers
- Snap ring pliers

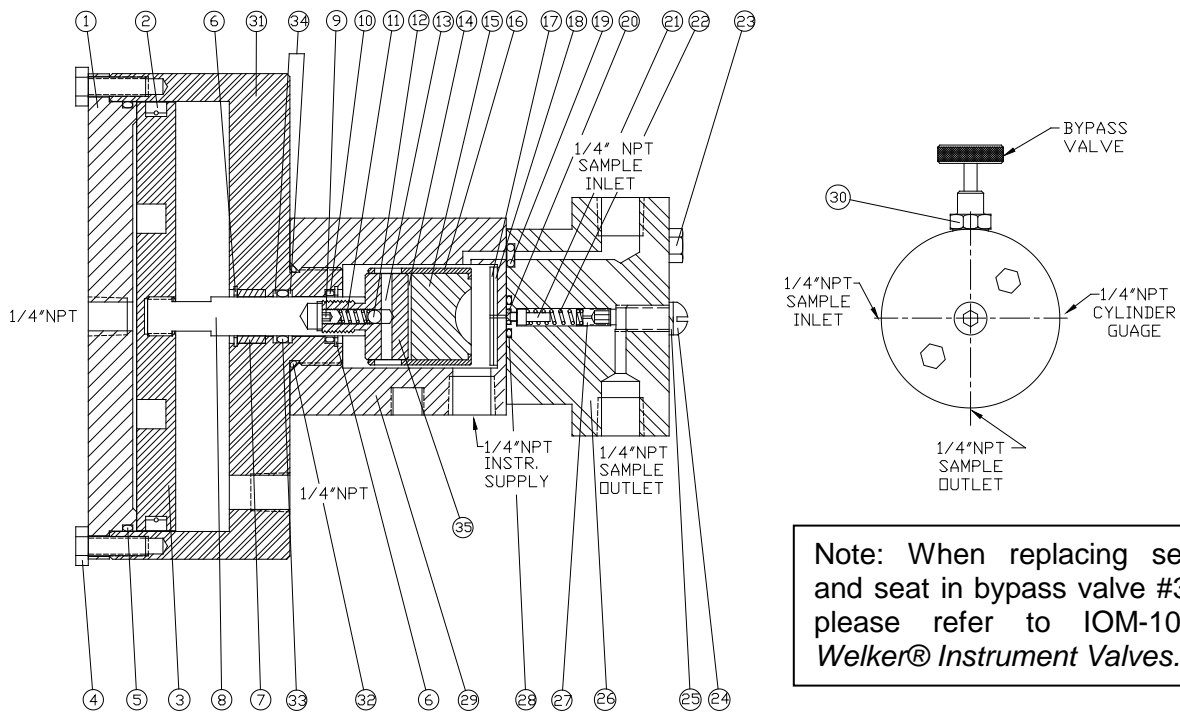

FIGURE 4

3.2 Instructions

- 3.2.1 Close the pipeline isolation valve and vent all pressure from the unit.
- 3.2.2 Disconnect the instrument supply tubing from the sampler body #29.
- 3.2.3 Relieve and disconnect all the tubing from the sampler to the sample cylinder.
- 3.2.4 Unscrew the complete motor housing from the sampler body (see Figure 5).

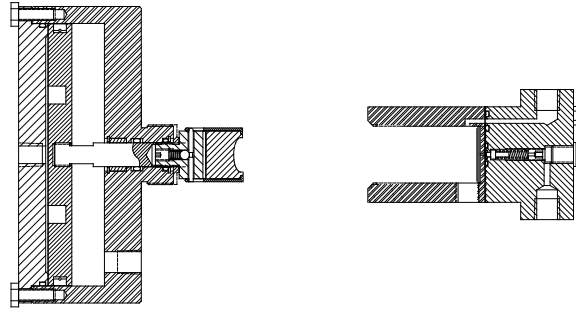

FIGURE 5

3.2.5 To replace the collection head #15, push the holding pin #13 out (it is held in place by spring tension) and slip the shield #16 off the shield/shaft adapter #35. Push the collection head out of the shield. The non-extrusion disc #14 will come out first and does not need to be replaced if it is in good condition (see Figure 6).

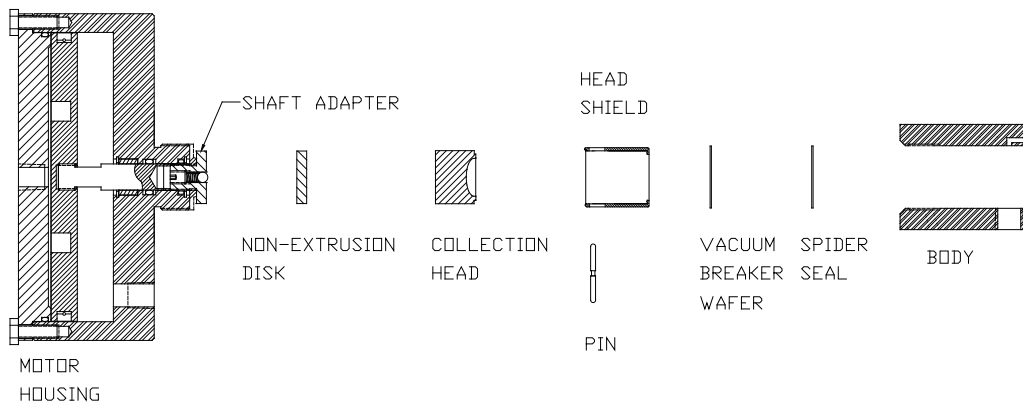

FIGURE 6

NOTE: All collection heads are marked on the back side with the size, compound, and durometer. Take note of what you are replacing. i.e. "V-70 1.0" or "V74" is a 70 durometer Viton collection head, 1.0 cc in volume. Consult Welker for other compounds available.

3.2.6 Lightly lubricate the inside surface of the shield and push in the new collection head. Replace the non-extrusion disc.

- 3.2.7 Slide the shield back onto the shield/shaft adapter and push the hold pin back into place.
- 3.2.8 To replace the remaining seals, remove the hex head machine screws #4 (8 each) that hold the motor top and housing together.
- 3.2.9 Replace the seal in the motor top.
- 3.2.10 To unscrew the shield/shaft adapter, hold on to the motor housing. With a wrench, unscrew the adapter from the shaft (see Figure 7).

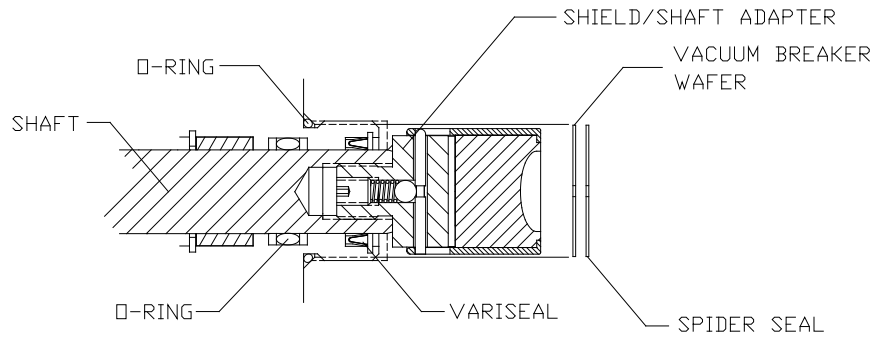

FIGURE 7

- 3.2.11 Carefully push the shaft #8 through the motor housing until the piston #3 clears the housing. Then, pull the piston and shaft out from the top (see Figure 8).

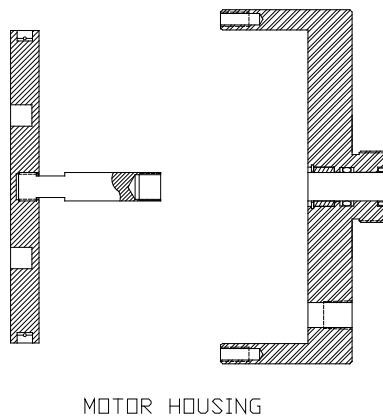

FIGURE 8

- 3.2.12 Examine the shaft #8 for damage. The shaft is polished and should be free of scratches and pits. If it needs to be replaced, place the piston #3 in a vise and remove the shaft with an adjustable wrench on the shaft flats. Replace and tighten securely.
- 3.2.13 Replace the seal on the piston.
- 3.2.14 From the body side of the motor housing #31, remove the snap ring #6 and the bal-seal #10. When replacing the bal-seal, be careful not to damage it.
- 3.2.15 Reinstall the snap ring.
- 3.2.16 Remove the snap ring #6 from the opposite side of the motor housing.
- 3.2.17 With the bearing removed replace the seals.
- 3.2.18 The bearing #7 should not need replacing; however, if it is damaged, replace the bearing.
- 3.2.19 Reinstall the snap ring.
- 3.2.20 Lubricate the shaft, and push the assembly back into the case, carefully guiding it through the seals. Replace the shield/shaft adapter securely.
- 3.2.21 Replace the motor top and install the hex head machine screws. Tighten all screws securely.
- 3.2.22 Replace the collection head assembly and holding pin.
- 3.2.23 Remove the vacuum breaker disc #17 and Kel-f[®] seal #18 from the body and replace, if necessary. These are free floating in the body and simply need to be installed with the seal first and then the metal disc.

NOTE: The metal disc will be exposed to the collection head.

3.2.24 Replace the seal #32 on the motor housing and screw the motor #31 back to the body (hand tighten only).

3.2.25 Replace instrument tubing.

3.2.26 Reconnect tubing to the sample cylinder and check for leaks.

4. INLINE RELIEF INSTRUCTIONS

4.1 General Information

The function of the inline relief is to assure that the sampler pumps the product into the cylinder and that, once the sample is taken, it cannot return to the pipeline even if the line pressure drops. The relief is located in the manifold/base #26 at the end of the sampler body. This relief is used with single-cavity and constant pressure type cylinders.

4.2 For Single-Cavity Cylinders

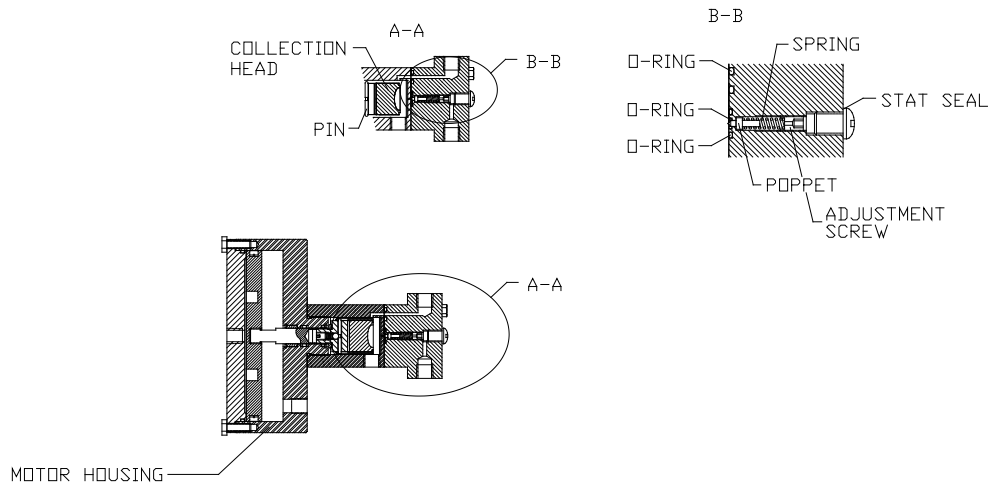

FIGURE 9

4.2.1 See Figure 9.

4.2.2 Remove the cap screw #24 and seal #25 from the end of the sampler manifold/base.

4.2.3 With a hex wrench, reach inside to the spring adjusting screw #27.

4.2.4 Make sure the sample cylinder inlet valve is closed. Slowly open pipeline isolation valve and allow full line pressure to the sampler.

4.2.5 Adjust the spring tension to where no gas is bleeding through the set screw. Then, turn adjusting screw another full turn clockwise.

NOTE: Each full turn on spring adjustment screw increases spring tension approximately 100 psi. The relief needs to be set approximately 100 psi above maximum line pressure.

4.2.6 Replace the seal #25 and cap screw.

4.2.7 The gauge on the manifold base should show 0 psi. This will assure the relief is holding and the sampler must pump product into the cylinder.

4.2.8 Reopen the cylinder inlet valve.

4.3 For Constant Pressure Cylinders

4.3.1 See Figure 9.

4.3.2 Determine maximum pipeline pressure (i.e., 750 psi).

4.3.3 Remove the cap screw #24 and the seal #25 from the sampler manifold base #26.

4.3.4 With a hex wrench, reach inside to the spring adjustment screw #27.

4.3.5 Close the sample cylinder inlet valve and open the pipeline isolation valve slowly to allow pipeline pressure to the body.

4.3.6 If the pipeline pressure is 200 psi or lower, adjust the spring setting to stop the gas from bleeding past the poppet. Then, replace the seal #25 and cap screw.

4.3.7 If the pipeline pressure is above 200 psi, adjust the spring setting to allow all but approximately 200 psi to flow past the poppet. Adjust the spring and replace the seal and cap screw. Look at the gauge. If pipeline pressure is 750 psi, the gauge should read approximately 550 psi. If it reads 650 psi, add more tension by turning the wrench one full turn clockwise. If the gauge reads 450 psi, relieve

tension by turning the wrench one full turn counter-clockwise. This may have to be repeated to reach an approximate relief setting of 200 psi.

NOTE: One full turn of the hex wrench equals approximately 100 psi.

4.3.8 Replace the seal and cap screw for the final time. Open the cylinder inlet valve.

4.4 Inline Relief Maintenance

4.4.1 Close pipeline isolation valve and relieve pressure from sampler.

4.4.2 Disconnect tubing and remove manifold base via hex head machine screws #23 (2 each).

4.4.3 Replace the three O-rings #19, #20 and #28 on the face.

4.4.4 Remove the spring adjustment screw, spring #22, and poppet #21. Examine the poppet sealing surface for damage. Replace, if necessary.

4.4.5 Reassemble the pieces and replace the sampler manifold/base into the body #29, making sure the face seals are in proper alignment to ports.

4.4.6 Replace the sample out tubing.

4.4.7 Relief is now ready to be reset.