



**Installation,
Operation,
and
Maintenance
Manual**

Welker[®] Automatic Insertion Device

Model
AID-9

The information in this manual has been carefully checked for accuracy and is intended to be used as a guide for the installation, operation, and maintenance of the Welker equipment described above. Correct operating and/or installation techniques, however, are the responsibility of the end user. Welker reserves the right to make changes to this and all products in order to improve performance and reliability.

13839 West Bellfort
Sugar Land, Texas 77498-1671
U.S.A.
Tel.: (800) 776-7267
Tel.: (281) 491-2331
Fax: (281) 491-8344
www.welkereng.com

This page intentionally left blank

TABLE OF CONTENTS

1. GENERAL	4
1.1 Introduction	4
1.2 Description of product.....	4
1.3 Specifications	6
2. INSTALLATION AND OPERATION	7
2.1 General	7
2.2 Preparing the unit for installation	7
2.3 Installing the unit.....	8
2.4 Helpful hints	9
2.5 Retracting the unit	9
3. MAINTENANCE	11
3.1 General	11
3.2 Disassembly instructions	12
3.3 Maintenance instructions.....	12
3.4 Reassembly	13
4. TROUBLESHOOTING	14

Welker®, Welker Jet®, and WelkerScope® are registered trademarks owned by Welker.

INTRODUCTION

1. GENERAL

1.1 Introduction

We appreciate your business and your choice of Welker products. The installation, operation, and maintenance liability for this product becomes that of the purchaser at the time of receipt. Reading the applicable *Installation, Operation, and Maintenance (IOM) Manual* prior to installation and operation of this equipment is required for a full understanding of its application and performance prior to use. If you have any questions, please call 1-800-776-7267 in the USA or 1-281-491-2331.

The following procedures have been written for use with standard Welker parts and equipment. Assemblies that have been modified may have additional requirements and specifications that are not listed in this manual.

Notes, Warnings, and Cautions



NOTE

Notes emphasize information or set it off from the surrounding text.



CAUTION

Caution messages appear before procedures that, if not observed, could result in damage to equipment.



WARNING

Warnings alert users to a specific procedure or practice that, if not followed correctly, could cause personal injury.

1.2 Description of product

The Welker Automatic Insertion Devices are designed for use in systems where it is desirable to insert and retract a probe within a pipeline while the pipeline remains pressurized. The design of the unit allows the operator to control the movement of the probe into and out of the pipeline safely through the use of four valves and an auxiliary gas supply, instrument air, or process fluid. For gas sampling applications, the unit should be installed on top of a straight section of piping before the flowing stream is subjected to turns and impingements that can result in turbulent flow. For liquid sampling applications, the device should be installed in a section of pipe where the process fluid is properly conditioned, such as downstream of a mixing device.

Oil Reservoir

The oil reservoir applies hydraulic oil on the insertion shaft piston in order to ensure a smooth insertion. Process or auxiliary pressure is applied to the reservoir in order to insert and retract the probe from the pipeline. The oil in the reservoir is then applied on the shaft as it travels into the pipeline. The reservoir is shipped from the factory with the necessary oil volume. It should also be noted that the unit is shipped from the factory with the assumption that the installation will be vertical. In cases where the unit is mounted horizontally, the operator will have to rotate the reservoir 90 degrees. Further instructions are given in step 6 of Section 2.2. **The internals of the reservoir will not function properly if the oil pot is placed in a horizontal position.**

SPECIFICATIONS

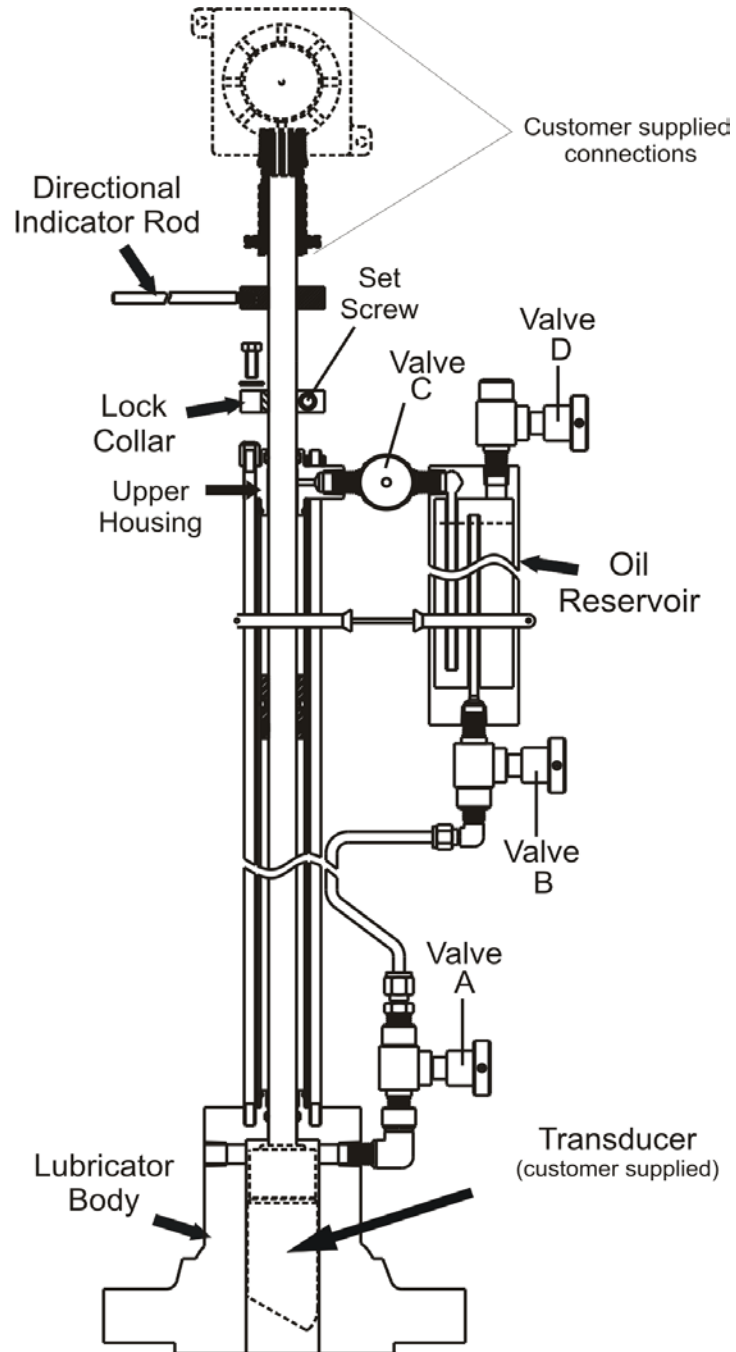

FIGURE 1

SPECIFICATIONS

1.3 Specifications

N NOTE

The specifications listed in this section are generalized for this equipment. Welker can modify the equipment according to your company's needs. However, please note that **the specifications may vary depending on the customization of your product.**

Table 1

General	
Products	Gases/ Liquids
Materials of Construction	316 Stainless Steel and Kalrez (others available)
Insertion Length	24" (609 mm)
Pipeline Connection	Flanged (NPT available)
Outlet Connection	Metric Thread Connection 15x1
Auxiliary Connections	1/4" FNPT
Maximum Allowable Pressure *	Refer to ANSI rating, Table 2 (for 316 SS)

Table 2

ANSI CLASS	MAXIMUM ALLOWABLE PRESSURE (at -20° F to 100° F/ -28° C to 37° C)
150	275 psi (18 bar)
300	720 psi (49 bar)
600	1440 psi (100 bar)
900	2160 psi (145 bar)

* Maximum allowable temperatures and pressures may be lower depending on the specifications of the pipeline connection device.

INSTALLATION & OPERATION

2. INSTALLATION AND OPERATION

2.1 General

After unpacking the unit, check it for compliance and for any damages that may have occurred during shipment.

N NOTE

Claims for damages caused during shipping must be initiated by the receiver and directed to the shipping carrier. Welker is not responsible for any damages caused from mishandling by the shipping company.

N NOTE

When sealing fittings with PTFE tape, refer to the proper sealing instructions for the tape used.

Recommended Tools

It would be advisable to have the following tools available for installation and retraction of the unit; however, tools used will vary depending on model.

- Measuring tape
- Small hex key set
- 6" adjustable wrench
- 10" adjustable wrench
- Flat blade screwdriver
- Permanent marker

2.2 Preparing the unit for installation

2.2.1 Make sure all valves on the unit are closed.

2.2.2 Line up the directional indicator rod with the flow entrance of the transducer (see Figure 1).

N NOTE

The directional indicator rod is used to determine the direction of the transducer once it is in the pipeline.

2.2.3 ***Determine the insertion length***

Before installing the device, the length the insertion shaft will need to travel inside the pipeline must be determined. Measure from the top of the pipeline's isolation valve to the center $\frac{1}{3}$ of the pipeline (see Figure 2).



Figure 2

INSTALLATION & OPERATION

2.2.4 Set the insertion length on the shaft

Once the insertion length of the shaft is determined, this length should be measured on the shaft itself.

- Pull up on the shaft to make sure it is fully retracted.
- Begin at the upper housing and measure up on the shaft to the desired length.
- Mark this point on the shaft, as this is where the lock collar will be positioned.

2.2.5 Position the lock collar

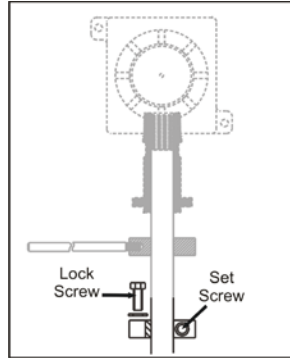

Figure 3

- Loosen the set screw (see Figure 3) in the lock collar, and move the collar to the position noted in the previous step.
- Position the lock screw so that it is aligned with its port in the upper housing.
- Tighten the set screw.

2.2.6 Using the oil reservoir in a horizontal position

- Loosen the fittings and detach the tubing between Valve B on the oil reservoir and Valve A on lubricator body.
- Loosen the screws in the clamp, and remove the clamp from the reservoir.
- Reposition the reservoir at a 90° angle, making sure Valve B is aimed downward.
- Measure a new piece of tubing to be connected from Valve A to Valve B.
- Replace the bolts and elbows onto the ends of the new tubing.
- Thread new fittings and replace tubing from Valve A to Valve B.

2.2.7 Using instrument air or an auxiliary gas supply

If the sample taken comes from a pipeline with a liquid or toxic gas, you will need to use an alternative source for pressure.

- Detach the tubing between Valve B and Valve A.
- Remove Valve A from the lubricator body.
- Plug the opening that is now in the lubricator body with a 1/4" NPT plug.
- Connect the auxiliary gas supply to Valve B.

2.3 Installing the unit

- Make sure all valves on the unit are closed.
- Connect the unit to the pipeline isolation valve.

INSTALLATION & OPERATION

- 2.3.3 If you are using an instrument air or an auxiliary gas supply, attach the auxiliary instrument to Valve B, which should still be closed.
- 2.3.4 **Slowly** open the pipeline isolation valve and check for leaks. If you are using an auxiliary gas supply, open the supply valve.
- 2.3.5 Open Valves A and B on the unit to allow pipeline pressure to enter the oil reservoir.



Valve D should always be closed when pipeline pressure is flowing through Valves A and B. Opening Valve D while pipeline pressure is flowing may cause the oil in the reservoir to erupt from the valve.

- 2.3.6 **Slowly** open Valve C, located between the oil reservoir and the upper housing. The shaft will now begin to insert into the pipeline.



Opening the valve too quickly may cause the shaft to insert harshly into the pipeline, possibly resulting in damage to the unit.



Once the shaft begins to move, there is no need to open the valve any further. This assures a slow and smooth insertion of the shaft into the pipeline.

- 2.3.7 Tighten the lock screw in the upper housing.
- 2.3.8 Close Valves A, B, and C and check for leaks.
- 2.3.9 Make the necessary electrical connections to the device.
- 2.3.10 The unit is now in service.

2.4 Helpful hints

- 2.4.1 Avoid rough handling of the unit and bending of the shaft. The shaft has a polished surface that travels through seals.
- 2.4.2 Operate the unit slowly and smoothly while inserting and retracting to avoid unnecessary slamming of the lock collar and/or the shaft piston located inside the unit.
- 2.4.3 The most common cause for repairs to an automatic insertion device is due to the pipeline isolation valve closing on the shaft while the shaft is still inserted into the pipeline. Please avoid this practice.
- 2.4.4 The entire unit should be treated with care.

2.5 Retracting the unit



All instrumentation attached to the unit must be shut down or disconnected prior to retracting.



Make sure all valves on the unit are closed prior to installation or removal.

INSTALLATION & OPERATION

2.5.1 Open valves A, B, and C to insure pressure is applied on the unit, and then close all valves.

N NOTE

Before retracting the unit, note the pipeline pressure required for insertion.

2.5.2 Shut down any electrical connections attached to the unit.

2.5.3 Loosen the lock screw in the lock collar in order to remove the lock collar from the upper housing. At this point, the shaft will remain inside the pipeline.

2.5.4 **Slowly** open Valve D. This will vent the air inside the oil reservoir into the atmosphere, relieving pressure on the insertion shaft.

! CAUTION

Valves A and B should always be closed when opening Valve D. Opening Valve D while pipeline pressure is flowing may cause the oil in the reservoir to erupt from the valve.

2.5.5 **Slowly** open Valve C to allow pressure to be relieved on the insertion shaft piston. The probe will now begin to retract from the pipeline.

N NOTE

Once the shaft begins to move, Valve C does not need to be opened any further. This assures a slow and smooth retraction of the probe.

2.5.6 When the probe has completely retracted from the pipeline, close the pipeline isolation valve, cutting off any pressure flowing into the unit.

2.5.7 If you are using instrument air or an auxiliary gas supply, close the supply valve.

N NOTE

If the probe needs to be withdrawn from the pipeline but the unit itself does not need to be removed from the pipeline, stop at step 7.

2.5.8 If needed, remove the unit from the pipeline isolation valve.

2.5.9 If you are using instrument air or an auxiliary gas supply, disconnect the supply from the unit.

2.5.10 The unit is now ready for maintenance or to be moved to another location.

MAINTENANCE

3. MAINTENANCE

3.1 General

Prior to maintenance or disassembly of the unit, it is advisable to have a repair kit handy for the system in case of encountering unexpected wear or faulty seals. All maintenance and cleaning of the unit should be done on a smooth, clean surface.

N NOTE

We recommend that the unit have annual maintenance under normal operating conditions. In the case of severe service, dirty conditions, excessive cycling usage, or other unique applications that may subject the equipment to unpredictable circumstances, a more frequent maintenance schedule may be appropriate.

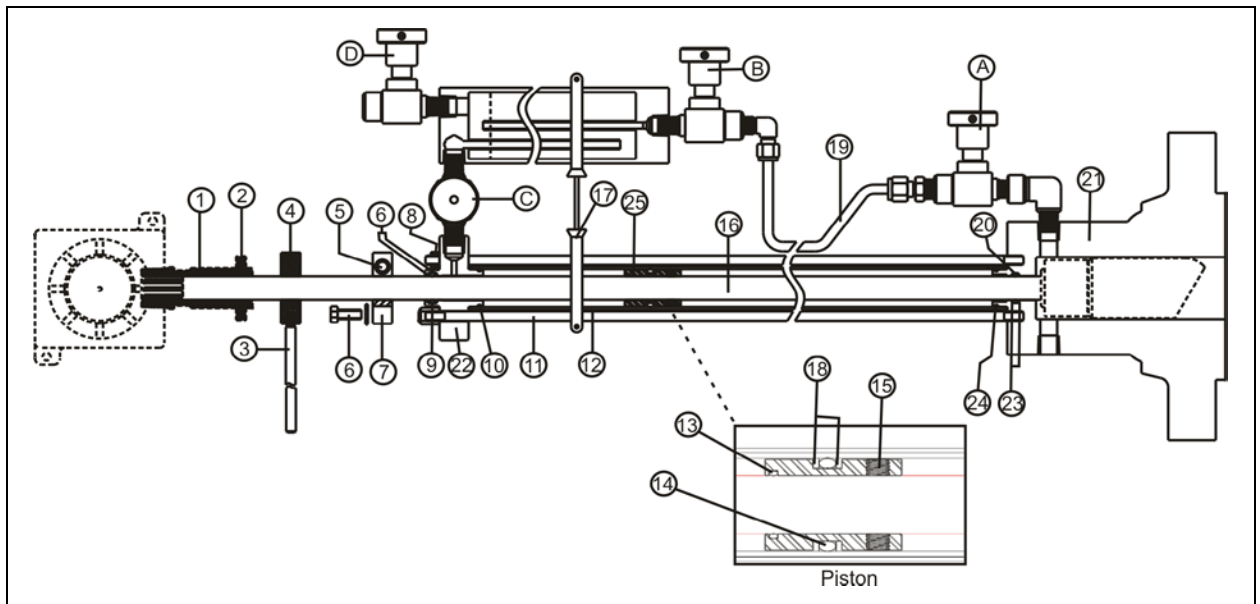

FIGURE 4

Refer to this figure throughout the entire maintenance process.

Recommended Tools

It would be advisable to have the following tools available for maintenance of the unit; however, tools used will vary depending on model.

- Small hex key set
- 6" adjustable wrench
- 10" adjustable wrench
- Flat blade screwdriver
- Hydraulic oil
- Dow Corning 111 lubricant

MAINTENANCE

3.2 Disassembly instructions

- 3.2.1 Close Valves B, C, and D on the oil reservoir and Valve A on the lubricator body (Part 21).
- 3.2.2 Disconnect the tubing between Valves A and B (Part 19).
- 3.2.3 Loosen the screws in the oil reservoir's clamp (Part 17), and remove the clamp from the reservoir.
- 3.2.4 Use an adjustable wrench on the body of Valve C to remove the oil reservoir from the upper housing (Part 22).
- 3.2.5 Remove all electrical connections and instrumentation from the device.
- 3.2.6 Loosen the set screw (Part 2) in the adapter (Part 1) and remove the adapter from the shaft (Part 16).
- 3.2.7 Remove the directional indicator rod (Part 3) from the shaft.
- 3.2.8 Loosen the set screws (Part 5) in the lock collar (Part 7) and slide the collar off the shaft.
- 3.2.9 Loosen and remove the tie bolt nuts (Part 8).
- 3.2.10 Slide the upper housing (Part 22) off the shaft.
- 3.2.11 Slide the cylinder (Part 12) off the end of the shaft.
- 3.2.12 Mark the end of the cylinder for orientation purposes during reassembly.
- 3.2.13 Remove the tie bolts (Part 11).
- 3.2.14 Remove the set screws (Part 15) on the piston assembly (Part 25) and slide the piston assembly off the shaft.
- 3.2.15 Slide the insertion shaft out of the lubricator body.

3.3 Maintenance instructions



CAUTION

Do not dig into the metal surfaces of the parts when removing O-rings from the O-ring grooves. Scratching the sealing surface can result in a leak. If necessary, dig into the O-ring, and replace it during reassembly. If the sealing surface becomes damaged, use a 600-grit wet sand paper strip to smooth the surface, and then clean it.



NOTE

New seals supplied in spare parts kits are not lubricated. They should be lightly coated with lubrication grease (Dow Corning 111 [DC 111] grease or equivalent lubricant) before they are installed into the equipment. This helps with the installation of the seals while reducing the risk of damage when positioning them on the parts. After the seals are installed, some additional lubrication can be applied to the shaft or cylinder inner diameters to allow smooth transition of parts.

- 3.3.1 Examine the inner surface of the cylinder (Part 12) for a smooth finish. If there are any pits or major scratches, the seals will leak. Call Welker for service options.
- 3.3.2 Examine the shaft (Part 16) and the outer surface of the cylinder for a smooth finish.
- 3.3.3 Replace the backup (Part 6) and the O-rings (Parts 9 and 10) in the upper housing.
- 3.3.4 Replace the backup (Part 18) and the O-rings (Part 13 and 14) in the piston.
- 3.3.5 Replace the backup (Part 23) and the O-rings (Parts 20 and 24) in the lubricator body.
- 3.3.6 ***Adding oil to the oil reservoir***
The unit is shipped from the factory with the necessary oil volume. If oil is needed, remove Valve D, and add oil until the reservoir is $\frac{3}{4}$ full. Replace Valve D.

MAINTENANCE

N NOTE

Oil can be added while the unit is still assembled and attached to a pipeline. To do so, depressurize the assembly, making sure all valves are closed before removing Valve D.

N NOTE

If oil needs to be added, it may be due to a leak in the unit.

3.4 Reassembly

- 3.4.1 Apply silicone grease to the threads of the insertion shaft.
- 3.4.2 Slide the shaft up through the bottom of the lubricator body (Part 21), being careful not to damage the seals.
- 3.4.3 Slide the piston (Part 25) down the insertion shaft until the set screw holes line up with the groove on the shaft.
- 3.4.4 Reattach the set screws (Part 5) securely.
- 3.4.5 Apply a small amount of silicone grease inside the bottom end of the cylinder.

N NOTE

The bottom end of the cylinder has a vent hole.

- 3.4.6 Carefully slide the cylinder (Part 12) on the shaft (Part 16), over the piston seals, and down onto the lubricator (Part 21).
- 3.4.7 Slide the upper housing (Part 22) down the insertion shaft and onto the cylinder.
- 3.4.8 Replace the tie bolts (Part 11) and tie bolt nuts (Part 8).
- 3.4.9 Reattach the oil pot assembly to the upper housing.
- 3.4.10 Replace the reservoir's clamp (Part 17) onto the reservoir and cylinder. Tighten the screws on the clamp.
- 3.4.11 Reconnect the tubing (Part 19) from Valve A to Valve B.
- 3.4.12 Slide the lock collar (Part 7) down on the insertion shaft.
- 3.4.13 Replace the directional indicator rod (Part 3) on the lock collar.
- 3.4.14 Reattach the adapter (Part 1) to the shaft and tighten the adapter's set screw (Part 2).
- 3.4.15 Reconnect the electrical box to the adapter.
- 3.4.16 Maintenance is now complete. Refer to steps 2.2.1 through 2.3.10 for reinstallation.

TROUBLESHOOTING

4. TROUBLESHOOTING

The following is a troubleshooting table of issues most commonly associated with the Welker® Automatic Insertion Device models. If you are having a problem that is not listed, or if the solution provided does not repair the problem, please call Welker for service options.

Table 3

PROBLEM	POSSIBLE CAUSE	SOLUTION
The shaft doesn't insert or retract smoothly.	Air may be trapped in the oil reservoir, or the reservoir may need oil.	Check to make sure the oil reservoir is $\frac{3}{4}$ full; vent any air trapped in the reservoir. <i>See step six in Section 3.3.</i> <i>See step four in Section 2.5.</i>
The oil reservoir needs to be refilled often.	Oil may be leaking past the piston seal.	Replace the piston seal, and reassemble the device. <i>See step four in Section 3.3.</i> <i>See Section 3.2 and 3.4.</i>
The probe will not retract from the pipeline.	<ul style="list-style-type: none"> • There may not be enough pressure in the pipeline to eject the probe. • The probe is bent inside the pipeline, possibly due to pipeline velocity or the isolation valve closing on the shaft while the shaft is still inserted in the pipeline. 	<ul style="list-style-type: none"> • Gently pull up on the shaft until it begins to retract. • The unit will need to be repaired or replaced. Call Welker for service options.

This page intentionally left blank



13839 West Bellfort, Sugar Land, Texas 77498-1671

Phone: (281) 491-2331

Fax: (281) 491-8344

Toll Free: (800) 776-7267

Web Page: www.welkereng.com