



*Installation, Operation, and  
Maintenance Manual*

***Welker<sup>®</sup> Constant Pressure Cylinder  
With Welker<sup>®</sup> Magnetic Indicator  
(Non-mixer)  
Model  
CP-42GA***

The information in this manual has been carefully checked for accuracy and is intended to be used as a guide for the installation, operation, and maintenance of the Welker equipment described above. Correct operating and/or installation techniques, however, are the responsibility of the end user. Welker reserves the right to make changes to this and all products in order to improve performance and reliability.

13839 West Bellfort  
Sugar Land, TX 77498-1671  
(281) 491-2331 - Office  
(800) 776-7267 - USA Only  
(281) 491-8344 - Fax  
<http://www.welkereng.com>

# TABLE OF CONTENTS

---

<b>1.</b>	<b>GENERAL</b>	<b>3</b>
1.1	INTRODUCTION	3
1.2	DESCRIPTION OF PRODUCT	4
1.3	IMPORTANT INFORMATION	4
1.4	COMPONENT DIAGRAM	5
1.5	SPECIFICATIONS	6
<b>2.</b>	<b>INSTALLATION &amp; OPERATIONS</b>	<b>7</b>
2.1	IMPORTANT INFORMATION	7
2.2	PRE-CHARGING THE CYLINDER	8
2.3	PURGING THE SYSTEM	10
2.4	SPOT SAMPLING	10
2.5	CONTINUOUS SAMPLING	11
<b>3.</b>	<b>MAINTENANCE</b>	<b>13</b>
3.1	GENERAL	13
3.2	DISASSEMBLY	14
3.3	MAINTENANCE	16
3.4	REASSEMBLY	16
3.5	CYLINDER CLEANING	17
	<b><u>SAFETY ISSUE WARNING FOR LIQUID SAMPLE CYLINDERS</u></b>	<b>18</b>
<b>4.</b>	<b>TROUBLESHOOTING GUIDE</b>	<b>19</b>

Welker®, Welker Jet®, and WelkerScope® are Registered Trademarks owned by Welker, Inc.

# SPECIFICATIONS

---

## 1. GENERAL

### 1.1 INTRODUCTION

We appreciate your business and your choice of Welker products. The installation, operation, and maintenance liability for this product becomes that of the purchaser at the time of receipt. Reading the applicable *Installation, Operation, and Maintenance (IOM) Manual* prior to installation and operation of this equipment is required for a full understanding of its application and performance prior to use. If you have any questions, please call 1-800-776-7267 in the USA or 1-281-491-2331.

The following procedures have been written for use with standard Welker parts and equipment. Assemblies that have been modified may have additional requirements and specifications that are not listed in this manual.

#### Notes, Warnings, and Cautions

 **NOTE**

Notes emphasize information or set it off from the surrounding text.

 **CAUTION**

Caution messages appear before procedures that, if not observed, could result in damage to equipment.

 **WARNING**

**Warnings alert users to a specific procedure or practice that, if not followed correctly, could cause personal injury.**

# SPECIFICATIONS

---

## 1.2 DESCRIPTION OF PRODUCT

The Welker Constant Pressure Sample Cylinder is designed for use in systems where it is necessary to extract and isolate accurate product samples by maintaining a steady pressure from the pipeline to the cylinder. The cylinders are equipped with a magnetic indicator and a graduated scale set to specify the capacity of the device (see Figure 1, below). During sampling, when the magnetic indicator reaches the 80% mark, all sampling should be stopped. A pneumatic supply pre-charges the cylinder with pressure to correspond with pipeline pressure. Pre-charging allows the sample to be transferred to the cylinder without taking a pressure drop. An internal piston in the cylinder helps to purge out air and contaminants prior to taking the sample by displacement. During the purge process, the piston is pushed to the end of the cylinder, also preventing any other possible contaminants from entering. Burst discs relief valves and gauges are also included on each end cap of the device. In the event that the cylinder is overpressurized, these discs will rupture, relieving excess pressure from the cylinder.



*Figure 1*  
*CP 42*

## 1.3 IMPORTANT INFORMATION

### **W** WARNING

**Please read the following information in its entirety upon receiving the Welker equipment described above.**

- Never fill a cylinder completely full of hydrocarbon liquid or refrigerated gas. Always allow for at least 20% expansion. There is a red line at 80 %, but 100% is not marked due to the design of the cylinder.
- Protect the cylinder at all times and handle with care. It is a precision instrument and may contain a hazardous product as well as a valuable representation of your company's product.
- When analysis is complete, the cylinder should be emptied safely and in a safe area by opening the product inlet valve, allowing the pre-charge pressure to push the piston to the product end cap, emptying the cylinder.
- Welker recommends cleaning and leak testing of the cylinders after each use.

# SPECIFICATIONS

## 1.3 IMPORTANT INFORMATION (CONTINUED)

- Because of the design of the cylinder and the incorporated seals, the process of emptying the cylinder will simultaneously wipe the walls of the device clean. The end cap will also be purged clean prior to the next use.

## 1.4 COMPONENT DIAGRAM

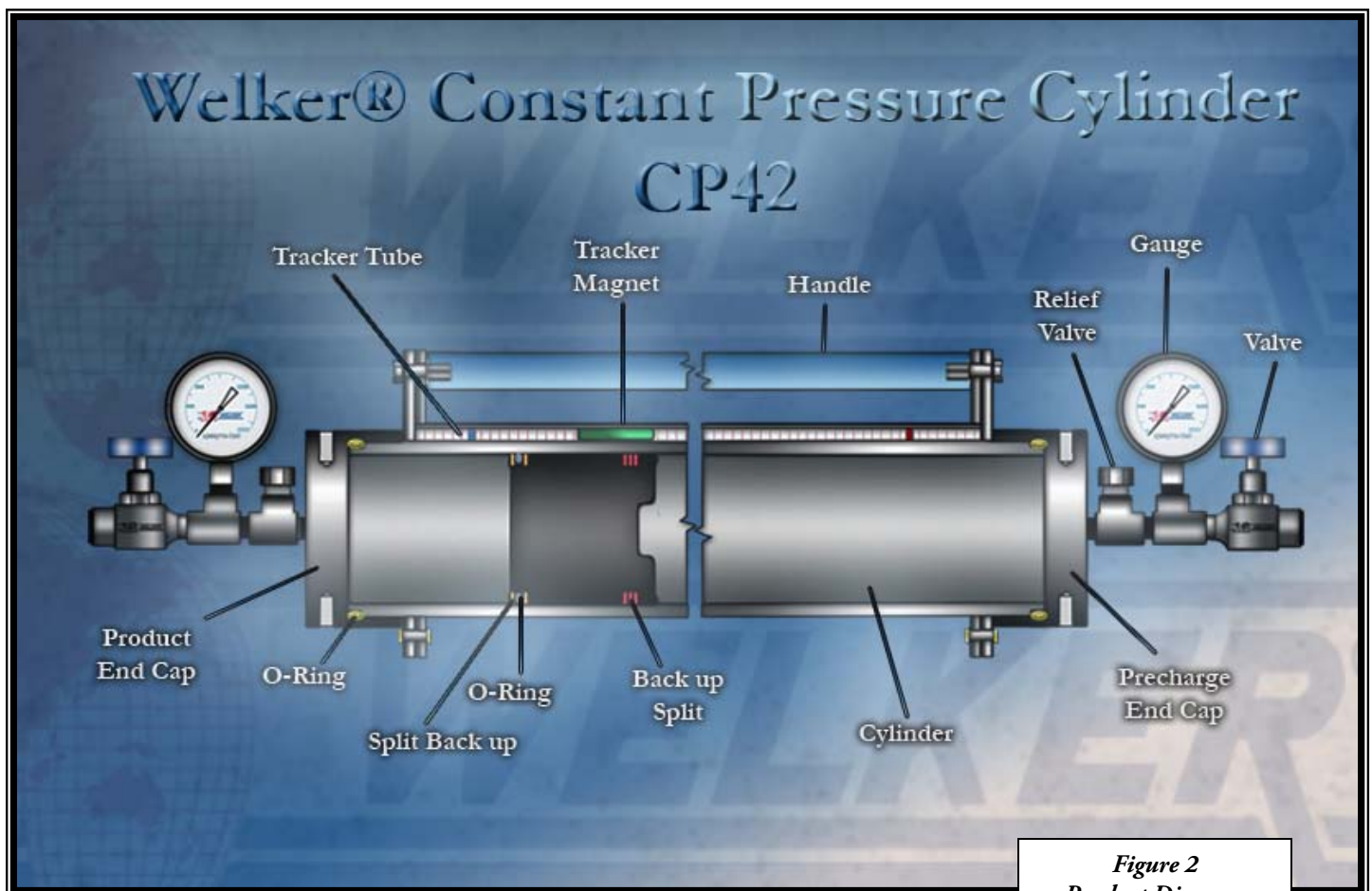

*Refer to above diagram throughout manual*

# SPECIFICATIONS

---

## 1.5 SPECIFICATIONS

### **N** NOTE

The specifications listed in this Section are generalized for this equipment. Welker can modify the equipment according to your company's needs. However, please note that **the specifications may vary depending on the customization of your product.**

**TABLE 1**

<b>Specifications</b>	
<b>Products Sampled:</b>	Crude oil, condensate, refined hydrocarbons, water, and all other gas or liquid products compatible with materials of construction.
<b>Materials of Construction:</b>	Anodized Aluminum, Viton <sup>®</sup> , PTFE (others available)
<b>Sample Volume:</b>	4,000cc
<b>Sample Inlet Connection:</b>	1/4" NPT
<b>Sample Outlet Connection:</b>	1/4" NPT
<b>Relief Valve Connection:</b>	1/2"-20 UNF (1/4" NPT available)
<b>Maximum Allowable Operating Pressure:</b>	1,800 psi @ -20°F to 100°F (124 bar @ -19°C to 38°C)

\*Maximum allowable temperatures and pressures may be lower depending on the specifications of the pipeline connection device.

# INSTALLATION & OPERATIONS

---

## 2. INSTALLATION & OPERATIONS

### 2.1 IMPORTANT INFORMATION

- After unpacking the unit, check it for compliance and for any damages that may have occurred during shipment.
- Claims for damages caused during shipping must be initiated by the receiver and directed to the shipping carrier. Welker is not responsible for any damages caused from mishandling by the shipping company.
- When sealing fittings with PTFE tape, refer to the proper sealing instructions for the tape used.
- There are two ends to the cylinder, separated internally by a floating piston. One end is marked PRODUCT INLET; this end can easily be identified by the small blue vertical line on the tracker tube. The other end of the cylinder is marked pre-charge end, and it is marked on the tracker tube with a small red vertical line at 80% full, the cylinder is 100% full when the piston reaches the end, however due to the design there is no mark.
- A sample probe should be located in the least turbulent area available of the flowing stream; i.e., not in a header or blow-down stack and away from obstructions, elbows or partially closed valves. The sample probe should be installed reaching approximately into the center one-third of the pipeline.
- The sample cylinder should be located as close to the sample point as possible.

#### Recommended Tools

It would be advisable to have the following tools available for installation of the unit. However, tools used will vary depending on cylinder model and connectors.



- Flexible hose or tubing
- (2) 6" adjustable wrenches
- Tubing cutters
- Small diameter stainless steel tubing

# INSTALLATION & OPERATIONS

---

## 2.2 PRE-CHARGING THE CYLINDER



CAUTION

The pre-charge gas being used must be compatible with the seals in the cylinder. The relief valves and gauges must also be adequate for the pressures used when pre-charging.

### 1. Connecting the cylinder pre-charge valve to the pipeline (pressurized gas pipeline only):

- Use small diameter stainless steel tubing to connect from an available pipeline valve to the pre-charge inlet valve.
- Make sure all valves are closed on the sample cylinder.
- Open the pipeline isolation valve.
- Slowly open the pre-charge inlet valve.
- Slowly open the product inlet valve to relieve any pressure buildup. The piston will begin to move.

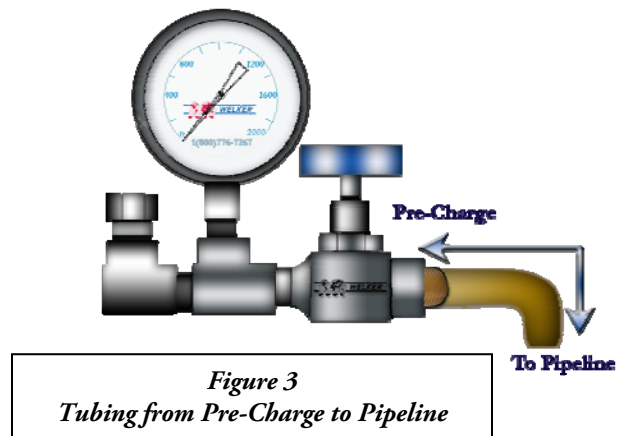

*Figure 3  
Tubing from Pre-Charge to Pipeline*



CAUTION

**Always open valves slowly to avoid slamming the piston from one end to the other.**

- The pre-charge gauge should begin to read pressure and will eventually reach pipeline pressure.
  - Once the piston has reached the end of the cylinder, close all valves and check for leaks.
  - Disconnect the tubing from the cylinder and from the pipeline isolation valve.
- ### 2. Connecting the pre-charge valve to the return port on a sampler probe (for continuous sampling):
- Install a valve into the return port of the sampler probe.
  - Make sure all valves are closed on the sample cylinder.



# INSTALLATION & OPERATIONS

## 2.2 PRE-CHARGING THE CYLINDER (CONTINUED)

- Use small diameter stainless steel tubing to connect from the cylinder's pre-charge inlet valve to the valve on the return port of the probe (see Figure 4).
- Open the valve on the return port of the sample probe.
- Slowly open the pre-charge inlet valve.
- Slowly open the product inlet valve to relieve any pressure buildup.
- The pre-charge gauge should begin to read pressure and will eventually read the pipeline pressure.
- Leave the pre-charge valve open during the sampling procedure.
- Leave the return port valve on the probe open during the sampling procedure.
- Check for leaks.

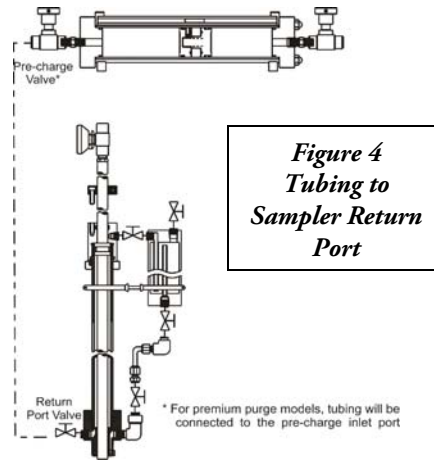

### 3. Using an auxiliary pre-charge gas:

#### **N** NOTE

When using an auxiliary gas, the pre-charge side of the cylinder should be pressurized with a regulated gas supply (i.e., nitrogen or helium) and **set 50-100 psi above pipeline operating pressure, not to exceed the maximum allowable pressure of the device.**

- Make sure all valves on the sample cylinder are closed.
- Use small diameter stainless steel tubing to connect the pre-charge valve to the regulated auxiliary gas supply.
- Open the valve on the gas supply.
- Slowly open the pre-charge inlet valve.
- Slowly open the product inlet valve to relieve any pressure buildup. The piston will begin to move.
- The pre-charge gauge should begin to read pressure and will eventually read the designated pressure.
- Once the piston has reached the end of the cylinder, close all valves and check for leaks.
- Disconnect the tubing from the cylinder and from the pipeline isolation valve.

# INSTALLATION & OPERATIONS

## 2.3 PURGING THE SYSTEM



**CAUTION**

If steps 2.2 Section 1 or 2.2 Section 3 are used to pre-charge, or if the cylinder is being used for continuous sampling and the pre-charge is not connected to the pipeline, it will be necessary to install an adjustable, reseating relief valve in order to relieve pre-charge pressure while continuous sampling.

1. If your cylinder is equipped with an adjustable relief valve (see Figure 5), use an auxiliary gas supply to set the valve at least 50-100 psi above pipeline pressure, not to exceed the maximum allowable working pressure indicated in Table 1 (refer to IO&M for relief valve).

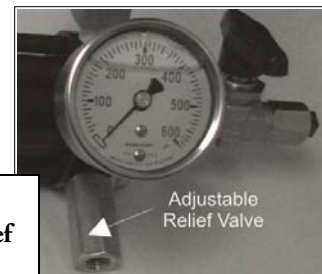

**Figure 5**  
**Adjustable Relief Valve**

2. Create a purge valve by tubing a T-fitting and valve inline between the sample point and the cylinder in order to provide a way to purge the system.



**NOTE**

Purging the system of excess air is important to ensure the system is not contaminated from the previous sample.

3. Close the product inlet valve.
4. Connect the product inlet valve to the sample point (i.e., probe or sampler).



**NOTE**

Refer to GPA-2166 (Gas Processors Association) and API 14.1 (American Petroleum Institute) sampling standards for guidance.

## 2.4 SPOT SAMPLING

1. Purge the system of any contaminants. Close the purge valve.
2. After pre-charging the cylinder above pipeline pressure (see Section 2.2), connect the product inlet valve of the cylinder to the sampler outlet port (see Figure 6).
3. Slowly open the sampler outlet valve.
4. Slowly open the product inlet valve on the product end cap. The piston will not yet move because pre-charge pressure is above pipeline pressure.

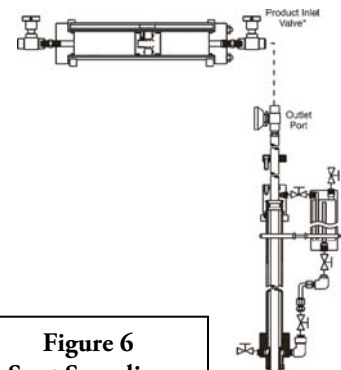

**Figure 6**  
**Spot Sampling**

# INSTALLATION & OPERATIONS

---

## 2.4 SPOT SAMPLING (CONTINUED)

5. With the sampler valve and product valve fully open, slowly open the pre-charge valve or pre-charge purge valve (for premium purge models) to relieve pre-charge pressure. This will allow the sampled product to enter the cylinder and push against the piston. Thus, no pressure loss is encountered.

**N** NOTE

Relieving the pre-charge too quickly can result in a pressure drop and an inaccurate sample. A bleed plug can be installed on the pre-charge valve to regulate the relieving rate. The bleed plug will allow only a small amount of pressure to exit, ensuring that pre-charge pressure is relieved steadily.

6. When the desired amount of sample is extracted, close all valves on the cylinder.
7. Close the probe outlet valve.
8. Carefully disconnect the cylinder from the probe, allowing the trapped product between the probe and cylinder valves to vent.
9. Plug or cap all valves on the cylinder.
10. Make a note of pressure, locations, etc., on the information tag according to company policy.
11. Check all fittings for leaks.
12. Place the cylinder into a carrying case to provide maximum protection during transportation. **Check with your company for transportation procedures and requirements; do not transport a constant pressure cylinder without following government regulations.**

## 2.5 CONTINUOUS SAMPLING

1. Pre-charge the sample cylinder (see Section 2.2) and connect the product inlet end of the cylinder to the sampler outlet port. If you have the premium purge model, connect the sampler from the outlet port to the product inlet port.
2. Open the product purge valve to purge the system of any contaminants. Close the purge valve. Welker recommends plugging the purge valve when not in use.
3. Open the sampler outlet valve.
4. Slowly open the product valve on the product end cap. The piston will not yet move because pre-charge pressure is above pipeline pressure.

**N** NOTE

The automatic sampler will push product against the piston, causing the pre-charge pressure to relieve from the adjustable relief and/or to be pushed into the pipeline.

5. Turn the sampler off when the cylinder is at 80% capacity. This allows a 20% margin for possible expansion due to temperature changes.
6. When the desired amount of sample is extracted, close all valves on the cylinder.

# INSTALLATION & OPERATIONS

---

## 2.5 CONTINUOUS SAMPLING (CONTINUED)

7. Close the sampler outlet valve.
8. Carefully disconnect the cylinder from the sampler, allowing the trapped product between the sampler outlet valve and the product inlet valve to vent.
9. Plug or cap all valves on the cylinder.
10. Record pressure, locations, etc., on the information tag according to company policy. Check all fittings for leaks.
11. Place the cylinder into a carrying case to provide maximum protection in transportation. **Check with your company for transportation procedures and requirements; do not transport a constant pressure cylinder without following government regulations.**

# MAINTENANCE

---

## 3. MAINTENANCE

### 3.1 GENERAL

Prior to maintenance or disassembly of the unit, it is advisable to have a repair kit handy for the system in case of unexpected wear or faulty seals. All maintenance and cleaning of the unit should be done on a smooth, clean surface.

#### Recommended Tools

It would be advisable to have the following tools available for installation of the unit. However, tools used will vary depending on cylinder model and connectors used.



- Spanner wrench or two  $\frac{3}{8}$ " diameter metal rods about 6 to 12 inches long
- (2) 6" adjustable wrenches
- 1 ft wooden dowel rod

#### **N** NOTE

We recommend that the unit have annual maintenance under normal operating conditions. In the case of severe service, dirty conditions, excessive cycling usage, or other unique applications that may subject the equipment to unpredictable circumstances, a more frequent maintenance schedule may be appropriate.

#### **N** NOTE

New seals supplied in spare parts kits are not lubricated. They should be lightly coated with lubrication grease (silicone grease or other) before they are installed into the equipment. This helps in the installation of the seals while reducing the risk of damage when positioning them on the parts. After the seals are installed, some additional lubrication can be applied to shafts or cylinder inner diameters to allow smooth transition of parts.

In the case of Constant Pressure Sample Cylinders, the lubrication grease should be applied sufficiently but lightly (Krytox<sup>®</sup> is preferred). Wipe excess lubrication from the seals as it may have an adverse effect on some analytical instrument results.

# MAINTENANCE

## 3.1 GENERAL (CONTINUED)

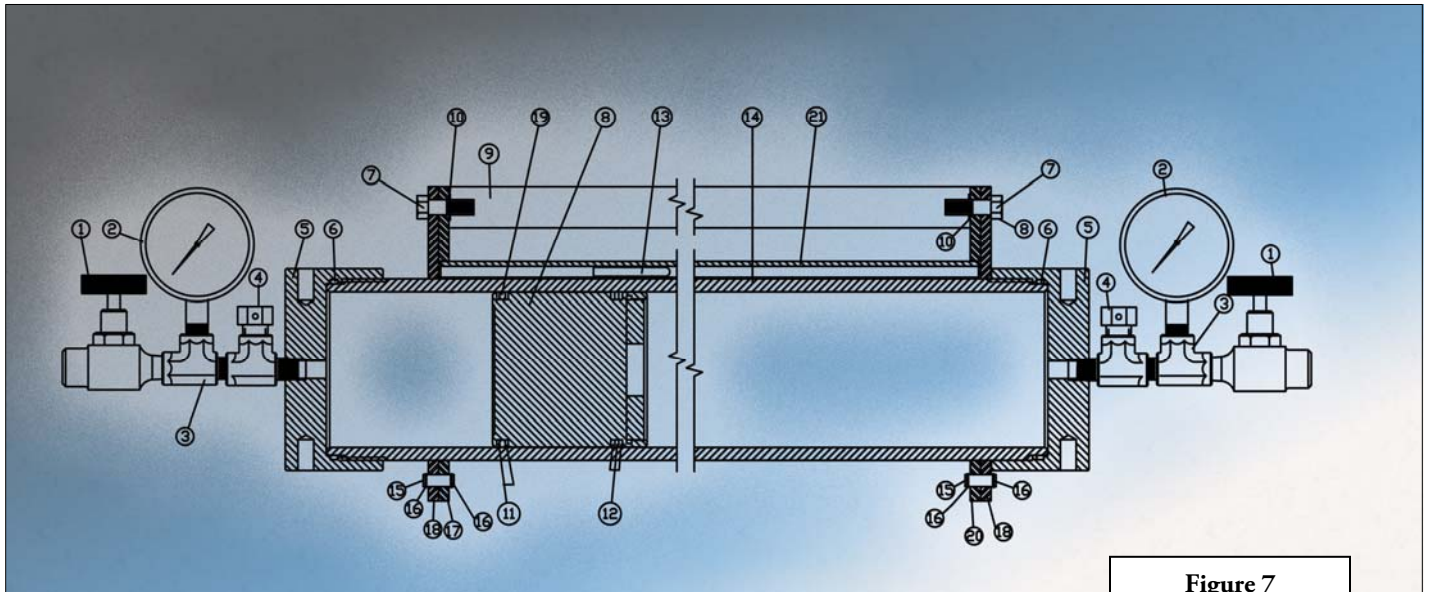

Figure 7  
Parts Diagram

CONSTANT PRESSURE CYLINDER CP-42GA					
1	Valve	8	Piston	15	Pin
2	Gauge	9	Handle	16	Snap Ring
3	Street Tee	10	Flat Washer	17	Front Bracket
4	Relief Valve	11	Back Up Spiral	18	Back Bracket
5	End cap	12	Back Up Split	19	O-ring
6	O-ring	13	Pin Tracker	20	Front Bracket
7	Hex Bolt	14	Cylinder	21	Tracker Tube

Refer to above diagram throughout maintenance process.

# MAINTENANCE

## 3.2 DISASSEMBLY

1. Make sure the unit is depressurized prior to maintenance.
2. Place a spanner wrench or two  $\frac{3}{8}$ " diameter metal rods in the two  $\frac{3}{4}$ " deep holes located 180° opposite each other in both the end caps (Part 5) and rotate the rods counter-clockwise to unscrew the end caps and remove them from the cylinder.

### **N** NOTE

Burst discs should be replaced after 6-10 cylinder fillings or at least once a year. While the discs do help to maintain the product, they are designed as a safety device to prevent overpressurization of the cylinder.

3. If necessary, remove and replace the burst discs from the burst disc relief valves (Part 4) on the end caps.
  - Insert the clear seal.
  - Insert the rupture disc after the clear seal. The dome should face out.
  - Torque the bursting relief caps to the proper specification (see Table 2).

Table 2

TORQUE SPECIFICATIONS FOR CYLINDER RUPTURE DISC CAPS		
Pressure Range (psi)	Torque Requirements	
0-300	50 in-lbs	5.6 Nm
301-5000	20 ft-lbs	27 Nm
5001-6000	24 ft-lbs	32 Nm
6001-7000	29 ft-lbs	39 Nm
7001-10,000	38 ft-lbs	52 Nm

4. If there is an adjustable relief valve on either end cap, remove it and replace all seals within the part (*refer to IO&M for adjustable relief valve*).



CAUTION

**Do not dig into the metal surfaces of the parts when removing O-rings from the O-ring grooves. Scratching the sealing surface can result in a leak. If necessary, dig into the O-ring, and replace it during reassembly. If the sealing surface becomes damaged, use a 600-grit wet sand paper strip to smooth the surface, and then clean it. Check the ball bearing for any signs of wear or damage. Replace if necessary.**

5. Remove the two hex bolts (Part 7), the two snap rings (Part 16), and the two pins (Part 15) to disassemble the handle (Part 9), brackets (Parts 18 & 17), and tracker tube (Part 21) assembly.
8. Push the piston (Part 8) out of the cylinder (Part 14) using a wooden dowel rod.



CAUTION

**Do not use a metal rod to remove the piston as it may scratch the surface of the cylinder.**

# MAINTENANCE

## 3.3 MAINTENANCE INSTRUCTIONS

1. Remove and replace the backups (Part 12 and Part 11), and the O-ring (Part 19) on the piston.
2. Remove and replace the seals (Part 6) in each end cap.
3. Wipe down the inside of cylinder using solvent (acetone or similar cleaning agent), and dry carefully (*also see Section 3.5*).
4. Closely examine the honed surface of the cylinder. Scratches and pits will cause the seals to leak.

### **W** WARNING

The following are causes to return the device to the manufacturer:

- Scratches or pitting that allow migration of gas from one side to the other.
- Any damage to the outside cylinder shell that may compromise the cylinder wall thickness.

## 3.4 REASSEMBLY INSTRUCTIONS

1. Slide the piston (Part 8) back into the cylinder taking care that the piston is pointed in the correct direction.
2. Reassemble the handle (Part 9), brackets (Part 18 & 17), and tracker tube (Part 21) assemble and tighten the two hex bolts (Part 7).
3. Reattach the burst disc relief valves (Part 4) to the end caps (Part 5).
4. Use the metal rods from Section 3.1 to screw the end caps (Part 5) back onto the cylinder (Part 14).
5. Pressure up cylinder (Part 14) at one end with an inert gas supply and test for leaks. Repeat the process from the opposite end. Pressurize slowly to avoid slamming the piston from one end to the other.

### **N** NOTE

Welker recommends using helium to test for leaks.

6. Maintenance is now complete. Refer to Section 2 for re-installation and operation instructions.

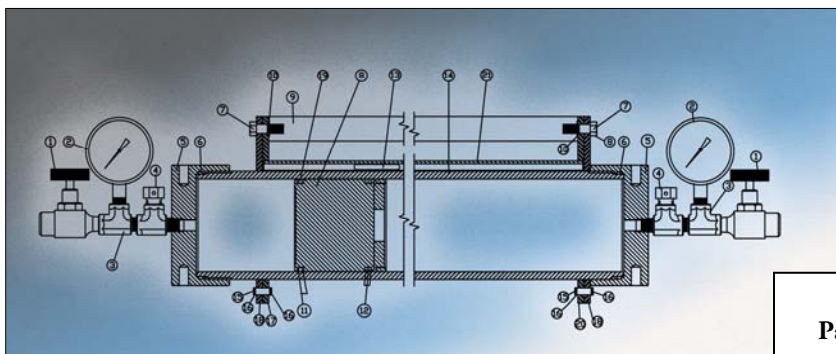

Figure 7  
Parts Diagram (Enlarged  
with Parts List on page 14)



# MAINTENANCE

---

## 3.5 CYLINDER CLEANING

Regular cleaning of the cylinder is essential for the proper functioning of the device. Solvent cleaning is normally done during scheduled maintenance; however, some companies require this before each cylinder is put into service. Any debris or residue that is not removed from the cylinder will contaminate the results of the next sample extracted from the cylinder. Welker recommends cleaning and leak testing of the cylinder after each use.

### **Cleaning a constant pressure sample cylinder can be done one of three ways:**

#### **1. Purging with helium**

- Fill and empty the cylinder with helium repeatedly.
- Take a sample of the helium to test for trace amounts of hydrocarbons.

#### **N** NOTE

If hydrocarbons are present in the analysis, the system has not been adequately cleaned, and further purging will be necessary. If hydrocarbons or contaminants remain present, a solvent cleaning may be required (*see step 3.5.3*). After cleaning with solvent, purge with helium to remove the solvent and analyze the helium to verify the solvent and hydrocarbons have been removed.

- If no hydrocarbons are found, cleaning is complete.
- Repeat step 5 of Section 3.4.

#### **2. Purging with new product**

- Purge the cylinder using the product to be sampled. This can be accomplished each time the cylinder is put into service.
- Repeat step 5 of Section 3.4.

#### **N** NOTE

This method is acceptable only if the cylinder will be used in one location.

#### **3. Cleaning with solvent**

- Fill and empty the cylinder repeatedly with solvent.
- Use an inert gas to dry and purge the cylinder.
- Use method 3.5.1 to verify the system is free of contaminants.
- Repeat step 5 of Section 3.4

# SAFETY WARNING

---

## SAFETY ISSUE WARNING FOR LIQUID SAMPLE CYLINDERS

After drawing the sample into the cylinder, the inlet and pre-charge valves should be closed. The sample line is then disconnected from the cylinder and the cylinder is completely isolated from the process. Paperwork is processed and the cylinder is prepared for transport. Prior to transporting the cylinder, it is a common and recommended practice to plug or cap the valves on the cylinder. These valves may terminate with a female NPT or a male NPT. The female valves are typically plugged, while the male valves are typically capped.

In the case of liquid sampling and due to the potential extremes of thermal expansion of many LPG products, caution should be taken to ensure that any residual liquid is drained, blown, or absorbed from the accessible exterior dead volume of the valve body (downstream of the seat) prior to plugging or capping the valve.

It is common to see temperature differentials of as much as 100° F (38° C) or more. Liquid samples that are drawn at -40° F to -50° F (-40° C to -46° C) can be transported in shipping cases that may see ambient temperatures as high as 100° F to 160° F (38° C to 71° C), and at times may exceed 160° F (71° C).

Operators should be familiar with the basic and general physical properties of the product that they are sampling so that they can adequately estimate the expansion potential of the sampled product within the cylinder and therefore have them allow ample outage for expansion to occur. In a majority of cases, 80% fill and 20% pre-charge is acceptable, but certain products may require a larger inert gas pre-charge ratio – i.e., 70%-30% or 60%-40%.



Burst discs are installed on these cylinders to protect them from structural failure. The operator must be aware that flammable product will be released in the event of overpressurization of the working pressure of the cylinder and therefore it is important to allow for ample expansion within the cylinder prior to attainment of the rupture disc activation. Burst disc ranges and cylinder working pressures are determined by the U.S. Department of Transportation, and these guidelines and rules are found in CFR-49.

If you have any questions, please contact Welker, Inc..

# TROUBLESHOOTING

## 4.0 TROUBLESHOOTING GUIDE

The following is a troubleshooting table of issues most commonly associated with the Welker Constant Pressure Cylinder models. If you are having a problem that is not listed, or if the solution provided does not repair the problem, please call Welker for service options.

PROBLEM	POSSIBLE CAUSE	SOLUTION
Gauge indicates a loss of pressure.	<ul style="list-style-type: none"> <li>• There is a leak from one of the fittings.</li> <li>• There is a leak from the burst discs.</li> <li>• The cylinder experienced a temperature drop.</li> <li>• There is a defective valve.</li> </ul>	<ul style="list-style-type: none"> <li>• Check all fittings for leaks with leak detector. Replace thread sealant.</li> <li>• Make sure the burst discs are torqued properly. If the problem persists, the discs may need replacement. <i>See Table 2.</i></li> <li>• Restore the temperature to pipeline temperature.</li> <li>• Repair or restore the defective valve.</li> </ul>
Pressure is leaking across the piston.	Seals in the piston are leaking.	Disassemble and clean the unit. Inspect cylinder for scratches. Replace seals in the piston and reassemble.  <i>See Sections 3.2-3.4.</i>
Pressure is leaking from the indicator rod.	Seals in the pre-charge end cap are leaking.	Disassemble the unit. Replace pre-charge end cap seals. Inspect the rod for scratches and reassemble.  <i>See Section 3.3.</i>
The pre-charge or product end cap is leaking.	<ul style="list-style-type: none"> <li>• The burst disc is leaking.</li> <li>• There is a loose fitting.</li> <li>• The seat on purge valve is leaking.</li> </ul>	<ul style="list-style-type: none"> <li>• Replace the burst disc. <i>See step 3.2 Section 13.</i></li> <li>• Tighten the fittings.</li> <li>• Replace the seat.</li> </ul>



**13839 West Bellfort, Sugar Land, Texas 77498-1671**

**Phone: (281) 491-2331**

**Fax: (281) 491-8344**

**Toll Free: (800) 776-7267**

**Web Page: [www.welkereng.com](http://www.welkereng.com)**