



Welker[®] Pitot Probe

Model

PP-1, PP-1W, PP-2, & PP-3

The information in this manual has been carefully checked for accuracy and is intended to be used as a guide for the installation, operation, and maintenance of the Welker equipment described above. Correct operating and/or installation techniques, however, are the responsibility of the end user. Welker reserves the right to make changes to this and all products in order to improve performance and reliability.

13839 West Belfort
Sugar Land, TX 77498-1671
(281) 491-2331 - Office
(800) 776-7267 - USA Only
(281) 491-8344 - Fax
<http://www.welkereng.com>

TABLE OF CONTENTS

1.	GENERAL	3
1.1	INTRODUCTION	3
1.2	DESCRIPTION OF PRODUCT	3
1.3	IMPORTANT INFORMATION	4
1.4	SPECIFICATIONS	4
1.5	SYSTEM DIAGRAM	5
2.	INSTALLATION & OPERATION	6
2.1	GENERAL	6
2.2	INSTALLATION OF PROBE WITH FLANGE CONNECTION	6
2.3	INSTALLATION OF PROBE WITH NPT CONNECTION	7
2.4	OPERATION	7
3.	MAINTENANCE	8
3.1	GENERAL	8
3.2	MAINTENANCE	8
4.	TROUBLESHOOTING	9
4.1	TROUBLESHOOTING GUIDE	9

Welker®, Welker Jet®, and WelkerScope® are Registered Trademarks owned by Welker, Inc.

SPECIFICATIONS

1. GENERAL

1.1 INTRODUCTION

We appreciate your business and your choice of Welker products. The installation, operation, and maintenance liability for this product becomes that of the purchaser at the time of receipt. Reading the applicable *Installation, Operation, and Maintenance (IOM) Manual* prior to installation and operation of this equipment is required for a full understanding of its application and performance prior to use.*

If you have any questions, please call 1-800-776-7267 in the USA or 1-281-491-2331.

Notes, Warnings, and Cautions



Notes emphasize information or set it off from the surrounding text.



Caution messages appear before procedures that, if not observed, could result in damage to equipment.



Warnings alert users to a specific procedure or practice that, if not followed correctly, could cause personal injury.

The following procedures have been written for use with standard Welker parts and equipment. Assemblies that have been modified may have additional requirements and specifications that are not listed in this manual.

1.2 DESCRIPTION OF PRODUCT

Welker Pitot Probes (PP-1 & PP-2) are designed to extract a sample of the fluid in a process from a designated point, create a flow loop through an instrument, and return to the pipeline via the same probe. The PP-1 series pitot probe is supplied as a probe with a specified process connection. The PP-2 series pitot probe is a PP-1 series sample probe with outlet (P1) and return (P2) valves. The PP-3 series pitot probe is a PP-2 series sample probe with two ball valves.

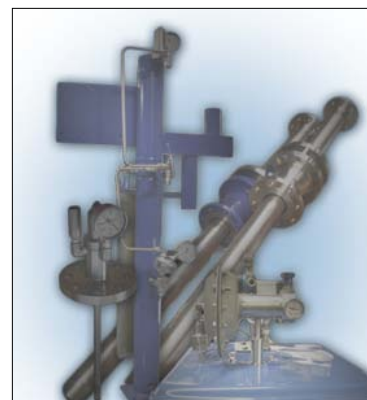

SPECIFICATIONS

1.3 IMPORTANT INFORMATION

N NOTE

For accurate sampling results, probe should not be installed in a header or blow-down stack and should be away from obstructions, elbows or partially closed valves.

1.4 SPECIFICATIONS

N NOTE

The specifications listed in this Section are generalized for this equipment. Welker can modify the equipment according to your company's needs. However, please note that **the specifications may vary depending on the customization of your product.**

Table 1

Specifications	
Materials of Construction:	PTFE, Stainless steel and Viton [®] with others available.
Maximum Allowable Operating Pressure:	MAOP will vary according to customer specifications of probe, please see assembly drawing for product, or contact Welker for this information.
Pipeline Connection:	Flanged or NPT
Outlet Ports:	¼" NPT with others available
Products Sampled:	Non-Toxic natural gas or other gases or liquids compatible with the materials of construction.

SPECIFICATIONS

1.5 SYSTEM DIAGRAM

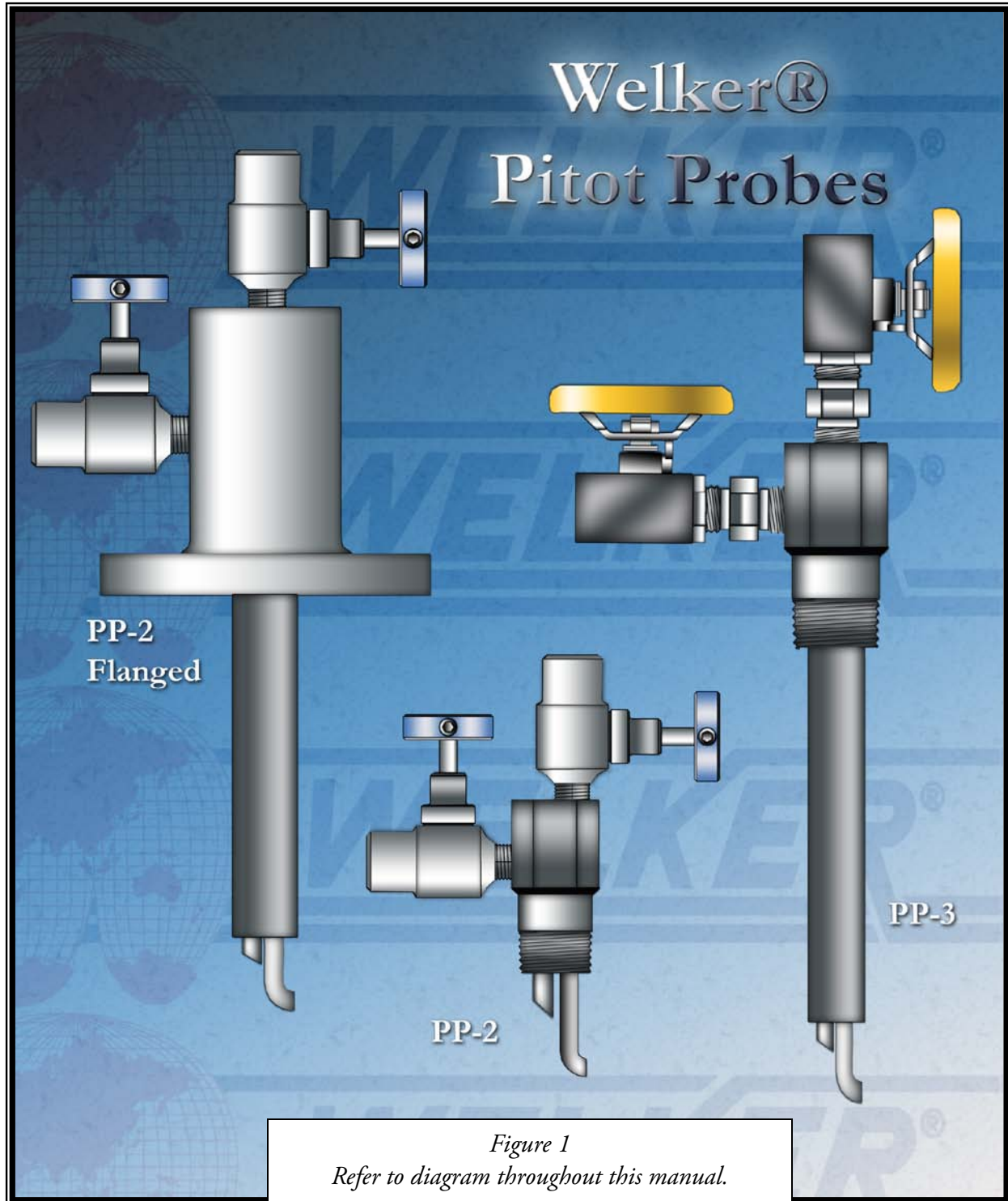

INSTALLATION & OPERATIONS

2. INSTALLATION & OPERATION INSTRUCTIONS

2.1 GENERAL

After unpacking the unit, check it for compliance and for any damages that may have occurred during shipment.

N NOTE

Claims for damages caused during shipping must be initiated by the receiver and directed to the shipping carrier. Welker is not responsible for any damages caused from mishandling by the shipping company.

2.2 INSTALLATION OF PROBE WITH FLANGE CONNECTION

(Refer to Figure 1 on page 5 & Figure 2 below)

W WARNING

Before installing the probe, make sure that the pipeline is depressurized.

1. Use the appropriate size gasket and position it properly for the connection being used.
2. Mount the probe to the mating flange connection on the pipeline. (If the sample probe is a wafer style (PP-1W see Figure to right), then mount the probe between the correct mating flanges on the pipeline.)
3. Install the bolts and nuts to the flanges.
4. Tighten the nuts to the proper torque specification for the particular flange size.
5. Close the valve on the probe.
6. Pressurize the pipeline and check for leaks.
7. The probe is now in service.

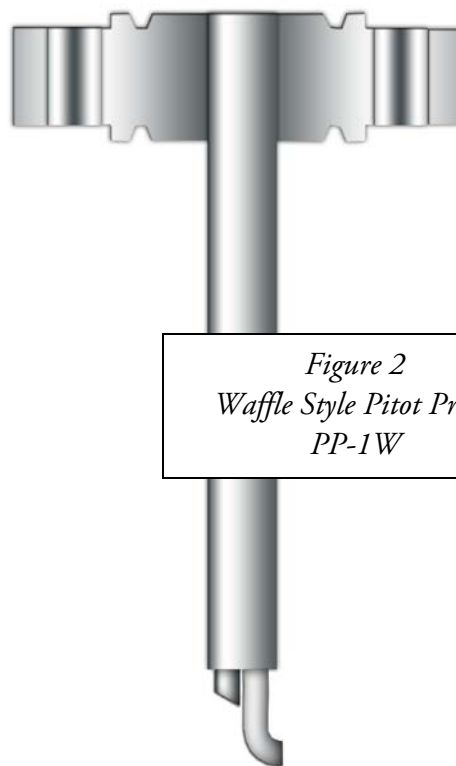

INSTALLATION & OPERATIONS

2.3 INSTALLATION OF PROBE WITH NPT CONNECTION

(Refer to Figure 2)

W WARNING

Before installing the probe, make sure that the pipeline is depressurized.

N NOTE

When sealing fittings with PTFE tape, refer to the proper sealing instructions for the tape used.

1. Mount the probe to the mating NPT connection on the pipeline.
2. Tighten the probe to the proper NPT depth gauge.
3. Close the valve on the probe.
4. Pressurize the pipeline and check for leaks.
5. The probe is now in service.

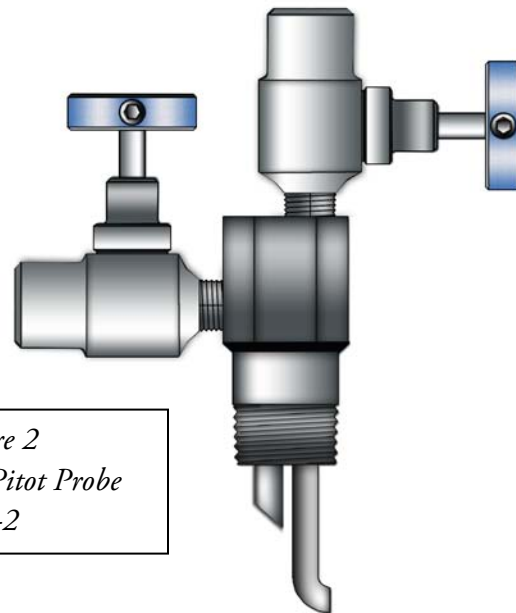

Figure 2
NPT Style Pitot Probe
PP-2

2.4 OPERATION

1. The only operation of the probe is to open and close the valve as needed when the appropriate equipment is connected to it.

MAINTENANCE

3. MAINTENANCE

3.1 GENERAL

Prior to maintenance or disassembly of the unit, it is advisable to have a repair kit handy for the system in case of unexpected wear or faulty seals. All maintenance and cleaning of the unit should be done on a smooth, clean surface.

3.2 MAINTENANCE

Recommended Tools

It would be advisable to have the following tools available for maintenance of the unit:

- Two adjustable wrenches (size of wrenches will depend on customer specifications of probe).

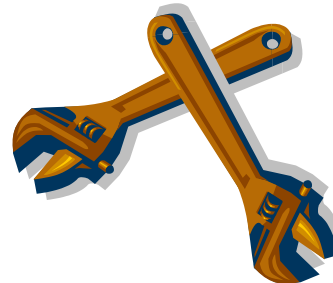

1. Maintenance needs to be performed to a probe only if the probe valve is leaking.
2. Depressurize the pipeline before performing any maintenance on the probe.
3. Close the probe valve.
4. Remove any equipment that is attached to the probe valve.
5. Remove the probe valve from the probe.
6. Rebuild or replace the probe valve.
7. Reattach the probe valve to the probe.
8. The probe is now ready for service.

TROUBLESHOOTING

4. Troubleshooting Guide

The following is a troubleshooting table of issues most commonly associated with the Welker Pitot Probe models. If you are having a problem that is not listed, or if the solution provided does not repair the problem, please call Welker for service options.

PROBLEM	POSSIBLE → CAUSE →	SOLUTION
Valve Leaking	<ul style="list-style-type: none">• Debris in valve• Worn or damaged O-rings and seat	<ul style="list-style-type: none">• Disassemble Valve and clean and replace O-rings if needed. (<i>See Section 3.2 maintenance for instructions</i>).• Replace Valve



13839 West Bellfort, Sugar Land, Texas 77498-1671

Phone: (281) 491-2331

Fax: (281) 491-8344

Toll Free: (800) 776-7267

Web Page: www.welkereng.com