

The Welker® OdorEyes® FTO provides a safe and effective way to odorize natural gas in low flow applications.

Features

- Effective natural gas odorization in low flow applications
- Designed for easy installation, operation, and maintenance

Benefits

- Cost effective
- Ease of use
- Low Maintenance



SPECIFICATIONS

FTO FARM TAP ODORIZER

FTO

Materials of Construction	Carbon Steel, Viton®
Inlet Port	½" FNPT
Outlet Port	½" FNPT
Run Connection	½" FNPT
Operating Pressure	1500 psig @ -20 °F to 120 °F

STANDARD OPTIONS

FTO FARM TAP ODORIZER

	CONTAINER SIZE	BYPASS	RUN CONNECTION
FTO	2		1
	.80 Gallon	0 or B	½" FNPT

BYPASS

- 0:** None
- B:** Carbon Steel

For custom options, choose **Plus Welker™**.



Customer Inspired. Welker Manufactured.
Collaborate with us to create a custom product unique to your application.

DIMENSIONS

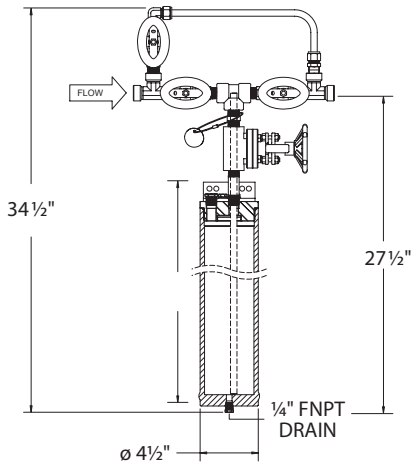

*Shown with bypass

Weight and/or dimensions are approximate.
Specifications subject to change without notice.

