

***Installation,
Operation
&
Maintenance
Manual***

***Welker[®] Light Liquid Hydrocarbon
Constant Pressure Sample Receiver
with Sample Pump***

***Model
LS-7***

The information in this manual has been carefully checked for accuracy and is intended to be used as a guide to operations. Correct operating and/or installation techniques, however, are the responsibility of the end user. Welker reserves the right to make changes to this and all products to improve performance and reliability.

13839 West Bellfort
Sugar Land, Texas 77498-1671
U.S.A.
Tel.: (800) 776-7267
Tel.: (281) 491-2331
Fax: (281) 491-8344
www.welkereng.com

Table of Contents

| | |
|---|-----------|
| 1. GENERAL..... | 3 |
| 1.1 Introduction..... | 3 |
| 1.2 Specifications..... | 3 |
| 2. INSTALLATION INSTRUCTIONS | 5 |
| 2.1 Installing the Sample System | 5 |
| 3. OPERATION | 8 |
| 3.1 Operation of the Sample System | 8 |
| 3.2 Mixing and Removing the Sample..... | 9 |
| 3.3 Removing Leftover Contents | 11 |
| 4. MAINTENANCE..... | 12 |
| 4.1 General..... | 12 |
| 4.2 Disassembly | 13 |
| 4.3 Reassembly | 14 |

Welker®, Welker Jet®, and WelkerScope® are Registered Trademarks owned by Welker Engineering.

1. GENERAL

1.1 Introduction

We appreciate your business and your choice of Welker products. The Installation, Operation and Maintenance liability for this product becomes that of the purchaser at the time of receipt. Reading the applicable IO&M Manual prior to installation and operation of this equipment is required so that you have a full understanding of its application and performance prior to commencement of use. If you have any questions, please call 1-800-776-7267 or 1-281-491-2331 in the USA.

The Welker Light Liquid Hydrocarbon Constant Pressure Sample Receiver with Sample Pump is designed with a large receiver to provide the adequate volume necessary to collect a representative sample of the flowing fluid. The cylinder sizes vary in volume based on flow rates, sample frequency, length of sample period, collection head size and/or the number of parties involved at the location that requires an individual portion placed in a transportation cylinder for analysis. Welker's original designed mixing system (an industry first) provides the best sample cylinder with mixing capabilities along with an ease of operation and maintenance.

1.2 Specifications

| | |
|----------------------------|--|
| Products Sampled: | Light liquid hydrocarbons, refined products, liquid petroleum gas, natural gas liquids, light crude and condensate |
| Materials of Construction: | Carbon steel, 316 stainless steel, aluminum, viton and PTFE |
| Viscosity Range: | 8 – 50° API Gravity |

Temperature Range: -20° F to 200° F (-28° C to 121° C)

Maximum Line Pressure: 2,160 psi (147 bar)

Sample Outlet Connection: 1/4" NPT

Power Connections: Specify

Area Classification: Can be used in hazardous areas

Utilities Required:

Air/Hydraulic Pressure: 65 – 100 psig (4.5 – 6.9 barg)

Air Consumption: 0.2 scf / cycle @ 75 psi

Options

- Other materials of construction
- Other volumes available
- Higher or lower pressure ranges
- Special coatings
- Electric mixer

2. INSTALLATION INSTRUCTIONS

2.1 Installing the Sample System

2.1.1 After unpacking the unit, check it for compliance and any damages that may have occurred during shipment.

NOTE: Claims for damages caused during shipment must be initiated by the receiver to the carrier. Welker is not responsible for any damages caused from mishandling by the shipping company.

NOTE: When sealing fittings with PTFE tape, refer to the proper sealing instructions for the tape used.

2.1.2 Locate the skid as close to the pipeline or sample point as possible.

2.1.3 When the unit is supplied with a sample pump mounted to the skid, the following steps are necessary (i.e., LSS-1, LSM-1, LSSM-1, etc.).

2.1.3.1 Install a pitot probe in the pipeline in a horizontal position. This reduces the effect of gravity that must be overcome if the probe is mounted vertically.

2.1.3.2 If single probes are used, install one of them upstream of a pressure drop and the other one downstream of that pressure drop (i.e., an orifice plate).

2.1.3.3 Tube from P₁ to the top port of the sampler body and from P₂ to the “T” in the bottom port of the sampler body. Use 3/8" stainless steel tubing.

2.1.3.4 Connect the air supply to the solenoid on the push-button actuation valve.

2.1.3.5 Open the valves on the probe and check for leaks.

2.1.4 When the unit is supplied with a probe-mounted sample pump, the following steps are necessary (i.e., LS-2, LSM-5, -6, -7, or -12, etc.).

- 2.1.4.1 Install the sample pump per instructions for the unit you have.
- 2.1.4.2 Connect the air supply to the solenoid attached to the sampler pump.
- 2.1.4.3 Tube from the sample out port of the sample pump to the sample inlet on the manifold block. Use 1/8" or 1/4" stainless steel tubing or high-pressure flex line.
- 2.1.4.4 Once the sample pump and tubing are pressured up, check for leaks.

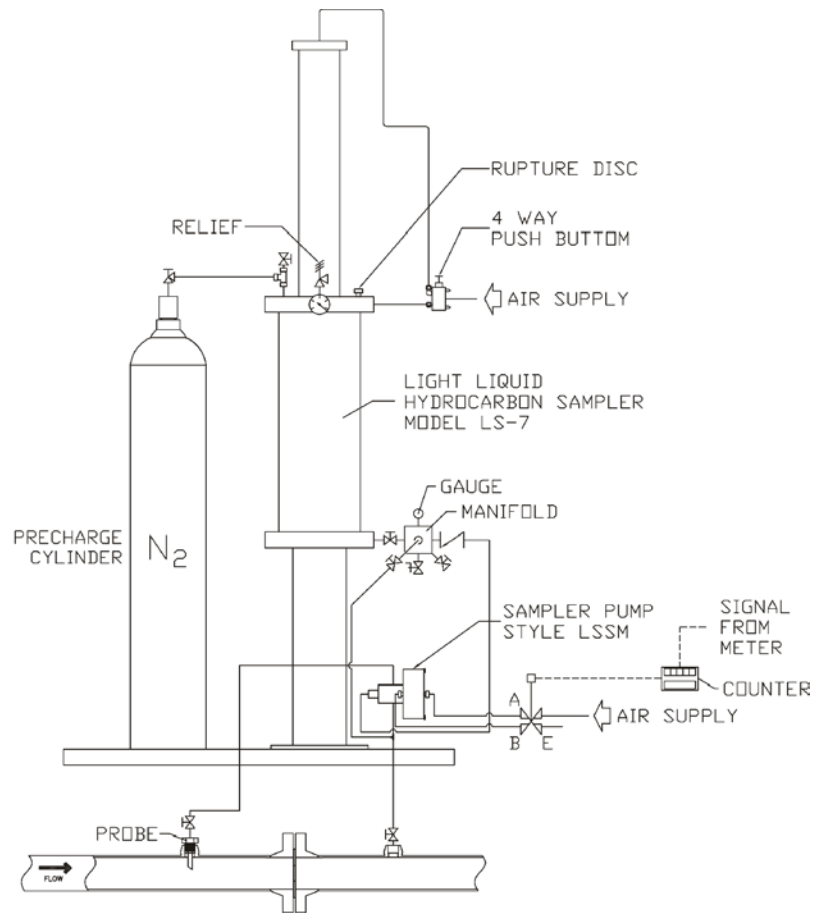

FIGURE 1

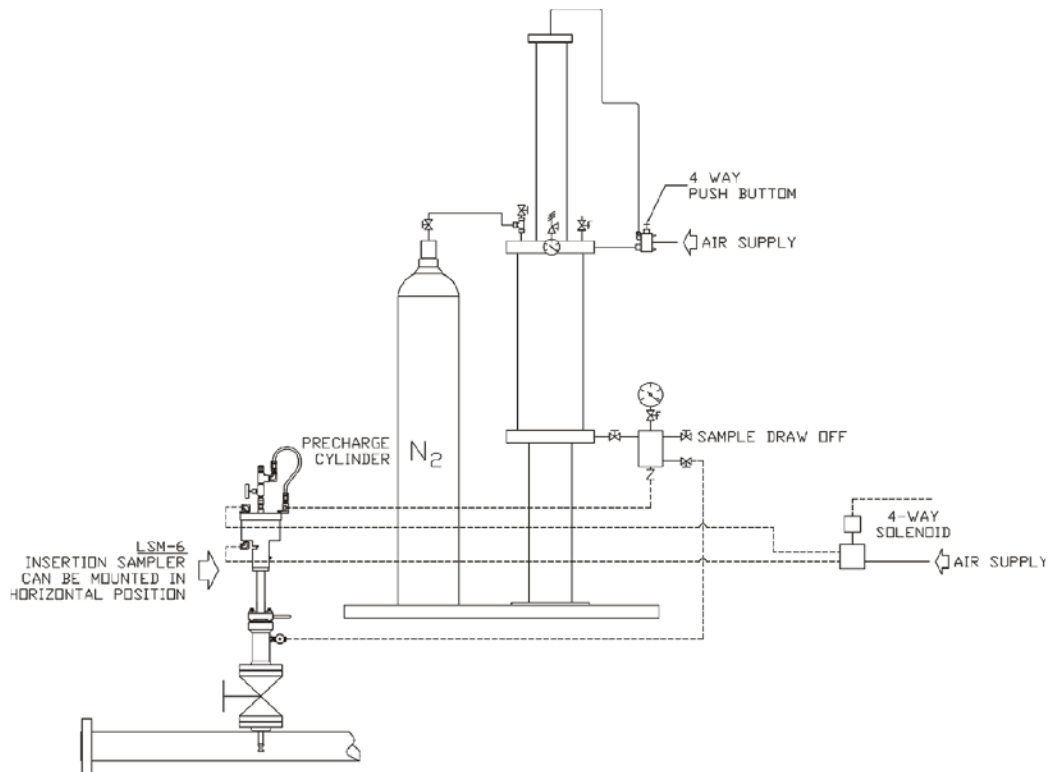

FIGURE 2

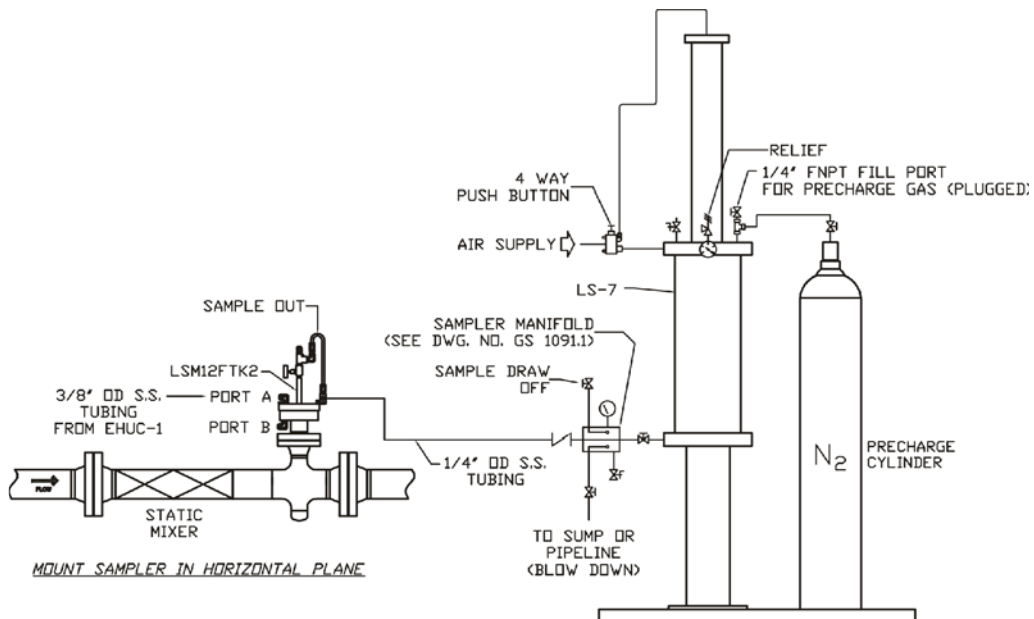

FIGURE 3

3. OPERATION

3.1 Operation of the Sample System

IMPORTANT: Never fill the LS-7 sample cylinder to capacity. Eighty percent capacity is recommended. This leaves room for expansion of the product.

The serial number on the sample pump will designate the volume of the collection head installed at the factory. This can aid in determination of the number of samples that need to be taken during a sample period to achieve 80% sample cylinder capacity.

3.1.1 Once the nitrogen cylinder has been filled, it should be made common by way of a valve with the pre-charge side of the LS-7 cylinder by opening the valve. This valve should remain open and is closed only during maintenance to the LS-7 cylinder.

3.1.2 Pressurize the unit to line pressure or up to 100 psi above line pressure using the fill and vent valve on the top flange of the LS-7 cylinder.

NOTE: The system must at least be pre-charged to a pressure above the vapor pressure of the lightest liquid to be sampled. Also, the nitrogen should not need recharging unless maintenance is required or a leak is present.

3.1.3 Check all fittings for leaks and plug the fill and vent valve.

3.1.4 Connect the appropriate timing system to the sampler. The pressure required for actuation of the sample pump is 65 psi and should never exceed 95 psi. Gas, air or hydraulic fluid are suitable supplies for the sample pump.

NOTE: The valve between the LS-7 cylinder and the manifold should always be open except when performing maintenance to the manifold or sample pump during a sample period. The instrument supply should be shut off prior to closing the valve between the LS-7 cylinder and the manifold because the sample pump could build excessive pressure

and damage internal parts. When this valve is closed, it will protect the collected sample during a maintenance procedure. Following maintenance of the sample pump or the manifold, reopen the valve prior to reactivating the instrument supply.

- 3.1.5 All other valves on the manifold should be closed during a sample period.
- 3.1.6 When the pipeline isolation valve is open to the sampler, the manifold gauge should read approximately 200 psi lower than pipeline pressure. The inline relief for the sampler is factory set at 200 psi. After the sampler has been actuated a few times, the pressure should build until equaling the pre-charge pressure. Once this happens, the LS-7 cylinder will slowly fill, thus moving the piston and piston indicator rod.
- 3.1.7 If the LS-7 system is supplied with a sample pump mounted on the skid, open the bypass valve and bleed a small amount of product from the draw-off valve. This will purge the manifold of any air.
- 3.1.8 Close both of these valves. The gauge will now read equal to pipeline pressure.
- 3.1.9 Check the manifold completely for leaks.
- 3.1.10 The system is now ready to begin a sample period.

3.2 Mixing and Removing the Sample

At the end of a sample period, observe the following steps:

- 3.2.1 Turn off the power/signal to the sampler.
- 3.2.2 Connect a transportation cylinder to the draw-off valve on the manifold block. The cylinder should have a pre-charge pressure equal to 100 psi above the product pressure in the LS-7 cylinder. (See the Welker Constant Pressure Cylinder IO&M for additional information.)

- 3.2.3 When product needs to be drawn off the LS-7 cylinder, the operator should fully cycle the mixer 4 to 5 times.
- 3.2.4 The mixer housing is rated to 125 psi. However, 75 psi should be enough pressure to provide a good mix.
- 3.2.5 When operating the 4-way mixing valve, do so such that the mixer travels the full distance of the liquid capacity in the LS-7 cylinder. If the LS-7 cylinder is only ½ full, then the magnet on the mixer should not be expected to travel the complete length of the cylinder to provide mixing. When the cylinder travels down and up once, that is a complete cycle.
- NOTE:** If the LS-7 cylinder is equipped with a proximity switch, then it should be swiveled back during the mixing operation so that it does not give a false signal.
- 3.2.6 When the mixing is complete, the mixing rod plate should be up against the bottom of the piston. The last air pressure from the 4-way mixing valve should be applied to the bottom of the LS-7 mixer actuation cylinder.
- NOTE:** The proximity switch should be turned back to its reading position when the transfer is completely finished.
- 3.2.7 Product is now ready to be removed from the LS-7 cylinder. The pre-charge pressure should be watched closely so that pressure can be added to keep the product at pipeline pressure. If the system is free of leaks, this will not be of concern.
- 3.2.8 Open the draw-off valve on the receiver, and open the inlet of the transportation cylinder.
- 3.2.9 Slowly crack open the purge valve on the transportation cylinder to purge any air, and shut the valve completely, when liquid appears.
- 3.2.10 Actuate the mixer for another 3 or 4 full cycles.

3.2.11 Slowly open the pre-charge valve on the transportation cylinder and allow liquid to enter until the cylinder is 80% filled, maintaining constant pressure during the transfer.

NOTE: This should be done slowly, so as to not take a pressure drop in the cylinder.

3.2.12 Close all valves and disconnect the transportation cylinder.

3.2.13 After the transfer is complete, all valves should be checked for leaks and plugged as a precaution. Record all required information onto the proper paperwork for sample transfer.

3.2.14 This procedure can be repeated to get full use of the sample in the LS-7 cylinder.

3.3 Removing Leftover Contents

To remove the remaining contents in the LS-7 cylinder, follow these steps:

3.3.1 Open the bypass valve on the sample manifold. If the pre-charge pressure is above pipeline pressure, it will force the contents back into the pipeline through the probe.

3.3.2 When the magnetic indicator is all of the way down, crack the draw-off valve momentarily to purge the manifold.

3.3.3 Close the draw-off valve and the bypass valve.

3.3.4 The unit is ready to resume sampling procedures once the instrument supply is reactivated.

4. MAINTENANCE

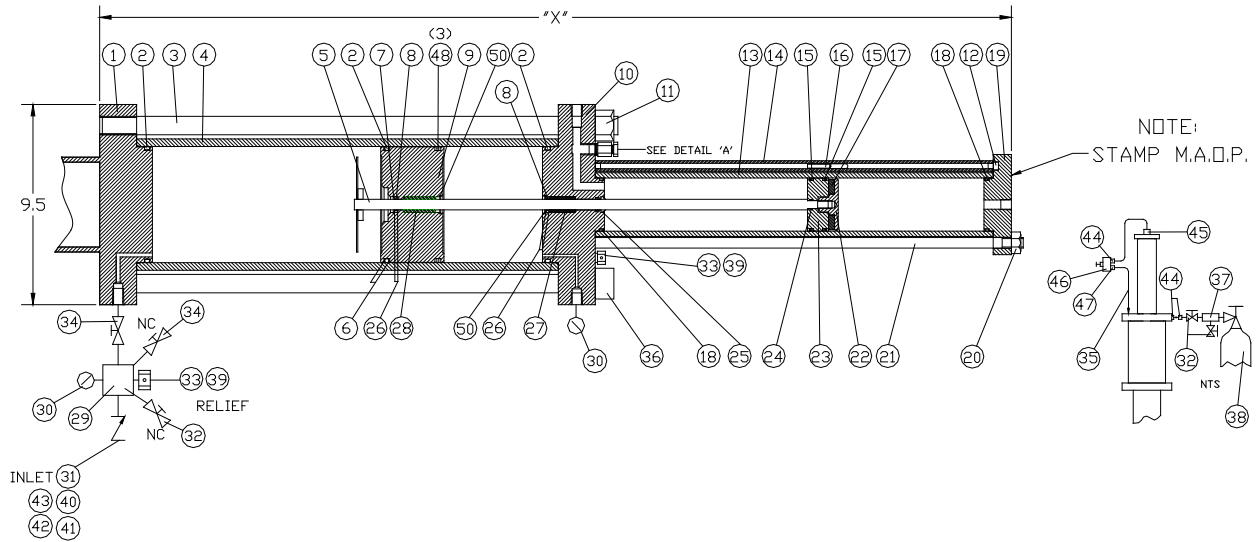

FIGURE 4

4.1 General

Prior to maintenance or disassembly of the unit, it is advisable to have a repair kit handy for the system in case of encountering unexpected wear or faulty seals.

We recommend that the unit have bi-annual maintenance under normal operating conditions. In the case of severe service, dirty conditions, excessive cycling usage or other unique applications that may subject the equipment to unpredictable circumstances, a more frequent maintenance schedule may be appropriate.

New seals supplied in spare parts kits are not lubricated. They should be lightly coated with lubrication grease (silicone grease or other) before they are installed into the equipment. This helps in the installation of the seals while reducing the risk of damage when positioning them on the parts. After the seals are installed, some additional lubrication can be applied to shafts or cylinder inner diameters to allow smooth transition of parts.

Before attempting to service the LS-7, the nitrogen cylinder valve should be closed to preserve the nitrogen in the cylinder. Then, make sure that the pipeline isolation valves are closed and the system has been completely depressurized.

The following tools will be required for disassembly and maintenance:

- 6" adjustable wrench
- 12" adjustable wrench
- External snap ring pliers
- Internal snap ring pliers
- 1 7/16" box end wrench (LS-7 A, B, C)
- 1 5/8" box end wrench (LS-7 D,E)

4.2 Disassembly

4.2.1 Disconnect or shut off the instrument air supply.

4.2.2 Make sure that all pressure has been released from the system.

4.2.3 Disconnect the tubing from the mixer portion and the tubing between the nitrogen cylinder and the LS-7 top flange #10.

4.2.4 Remove the nuts #20 (4) from the mixer actuator cylinder tie bolts #21 (4) and remove the top cap #19 of the mixer actuator.

4.2.5 Remove the tracker tube #14. Do not lose the tracker magnet #16 in the tracker tube, or the rubber end pieces #12 (2).

4.2.6 Replace the seal #18 on the top cap.

4.2.7 Slowly slide the mixing cylinder #13 up and off the mixing piston #23.

4.2.8 Remove the magnet retainer #22, magnet #17 and mixing piston from the mixer rod #5.

4.2.9 Replace the seals #15 (2) and #24 on the mixing piston.

- 4.2.10 Remove the nuts #11 (8) from the LS-7 cylinder tie bolts #3 (8).
- 4.2.11 Lift the top flange straight up and completely clear the mixing rod before pulling it away from the cylinder #4.
- 4.2.12 Replace the seals #2, #18, #25 and #26 (2) on the top flange.
- 4.2.13 Make sure that the bearing in the top flange is clean and smooth. Replace if necessary.
- 4.2.14 Remove the LS-7 tie bolts and carefully lift the cylinder off the bottom flange #1 and replace that flange seal #2.

NOTE: The cylinder is HEAVY!

- 4.2.15 Remove the mixer shaft from the piston #9 in the cylinder.

NOTE: Make sure not to bend the shaft when removing it from the piston.

- 4.2.16 Slowly push the sample piston out of the sample cylinder by reaching inside the pre-charge side. Note the top and bottom of the piston and cylinder.

NOTE: It may be helpful to have something to help push the piston out of the cylinder (2" x 4", length of pipe with a padded end, etc.)

- 4.2.17 Replace the seals #2, #6 (2), #8, #26 (2) and #48 (3) on the piston.
- 4.2.18 Make sure that the bearing in the piston is clean and smooth. Replace if necessary.
- 4.2.19 Examine all of the polished and honed surfaces on the mixer shaft and sample cylinder.

Deep pits and scratches will cause product and pressure to leak past the seals.

4.3 Reassembly

- 4.3.1 Lightly lubricate the inside of the sample cylinder.
- 4.3.2 Reinsert the sample piston into the sample cylinder.
- 4.3.3 Lightly lubricate the mixer shaft.

- 4.3.4 Reinsert the shaft into the sample piston carefully to avoid damaging the seals. Rotate the threads through the seals.
- 4.3.5 Place the cylinder back onto the lower flange with the correct orientation.
- 4.3.6 Reinsert and tighten the tie bolts.
- 4.3.7 Carefully replace the top flange.
- 4.3.8 Replace and tighten the tie bolt nuts.
- 4.3.9 Replace the mixing piston, magnet (correctly oriented) and magnet retainer.
- 4.3.10 Slide the mixing cylinder back down into place.

NOTE: Do not forget to replace the tracker magnet in the tracker tube.
- 4.3.11 Replace and tighten the mixing cylinder tie bolts.
- 4.3.12 Replace the top cap.
- 4.3.13 Replace and tighten the mixing cylinder tie bolt nuts.
- 4.3.14 Pressurize the LS-7 sample cylinder with an inert gas or air and check for leaks.
- 4.3.15 Release the pressure.
- 4.3.16 Reconnect the tubing to the mixing cylinder.
- 4.3.17 Re-pressurize the nitrogen system (see 3.1.1).
- 4.3.18 The cylinder is now ready to be reused.